

**AGENDA**  
**REGULAR BOARD MEETING - TOWN OF BOSTON**  
**MARCH 6, 2024 - 7:30 P.M.**

**ITEM NO. I PRELIMINARY MATTERS**

1. Call Meeting to Order
2. Roll Call
3. Pledge of Allegiance and Opening Prayer
4. Other Preliminary Matters

**ITEM NO. II REGULAR BUSINESS**

1. Correction and Adoption of the Minutes from February 7, 2024
2. Consideration of all Fund Bills

**ITEM NO. III CORRESPONDENCE**

1. Town Clerk's Report for January 2024
2. NYSEG and RG&E Remind Customers of Resources to Manage Energy Bills – February 7, 2024
3. NYSEG and RG&E Deliver Best Reliability in Five Years – February 14, 2024
4. NYSEG and RG&E Preparing for Widespread Wind Event Expected to Impact State – February 28, 2024
5. Letter from Erie County Department of Public Works – Notice of Road Closure, Cole Road between Ward Road and Old Lower East Hill Road
6. Letter from Erie County Department of Public Works – Notice of Road Closure, Boston State Road between Boston Cross Road and Liebler Road
7. Letter from the Boston Free Library – Lease & Depository Agreement for 2024
8. Letter from Erie County Water Authority – Lead and Copper Rule Revisions and Improvements
9. Letter from County Executive Poloncarz – NEST Solid Waste Management Plan 2020-2030
10. Letter from Erie County Legislator Mills – Supervisor Keding named President of Association of Erie County Governments 2024
11. Western New York Southtowns Scenic Byway – Buffalo Bills Partnership Proposal
12. Letter from Pinsky Law Group – Flat Fee Retainer: Service Awards Points Review
13. 2023 Annual Report on Revenues and Expenditures of Foreign Fire Insurance Premiums from Patchin Volunteer Exempt Fireman's Benevolent Association
14. Letter from National Fuel – Highway & Municipal Construction Projects

15. Use of Meeting Facility– Boston Democratic Social Club meetings
16. Use of Meeting Facility – Supervisor Keding LOSAP meeting
17. Use of Meeting Facility – Supervisor Keding Comprehensive Plan Committee meetings
18. Use of Meeting Facility – Supervisor Keding Comprehensive Plan Public meeting
19. Senior Agreement 2024 – Boston Seniors
20. Senior Agreement 2024 – Boston Young at Heart
21. 2023 Energy Benchmarking Report
22. Resignation letter from Deborah Catalano, Board of Assessment Review Member
23. Letter from Erie County Department of Senior Services regarding April 8<sup>th</sup> solar eclipse

#### **ITEM NO. IV NEW BUSINESS**

1. Requests from the Floor (3-minute time limit per person)
2. Resolution 2024-21 Indemnification and Hold Harmless Agreement Related to Gate in Easement Granted to Town
3. Resolution 2024-22 Referring Large-Scale Solar Project to Planning Board and Conservation Advisory Council for Review and Comment
4. Application for Use of Facility – Boston Free Library Fundraiser
5. Application for Use of Facility – Conservation Advisory Council - Birdhouse Workshop
6. Application for Use of Facility – Conservation Advisory Council – Fishing Derby
7. Application for Use of Facility – Trooper Brinkerhoff Foundation – 5K Race
8. Application for Use Sporting Facility – Boston Youth Soccer League

#### **ITEM NO. V OLD BUSINESS**

1. Resolution 2024-18 Repair, Coating, and Striping of Sports Courts

#### **ITEM NO. VI REPORTS AND PRESENTATIONS**

1. Highway Superintendent
2. Councilmembers
3. Town Clerk
4. Supervisor

#### **ITEM NO. VII ADJOURNMENT OF MEETING**

1. Adjournment of Meeting



REGULAR BOARD MEETING  
FEBRUARY 7, 2024

COPY

TOWN HALL  
7:30 P.M.

Present: Supervisor Jason Keding, Councilman Michael Cartechine, Councilwoman Jennifer Lucachik, Councilwoman Kelly Martin, and Councilwoman Kathleen Selby.

Also Present: Highway Superintendent Telaak, Attorney for the Town Costello, and Deputy Town Clerk Derk.

Supervisor Keding stated there are no Preliminary matters.

Supervisor Keding read the public hearing notice at 7:37 p.m.

TOWN OF BOSTON  
NOTICE OF PUBLIC HEARING

A public hearing shall be held by the Town Board of the Town of Boston on February 7, 2024, at 7:35 p.m., at Boston Town Hall, 8500 Boston State Road, Boston, New York, to hear any and all persons either for or against 2024 Local Law Intro. No. 1, entitled: "A LOCAL LAW To amend the Boston Town Code to add Chapter 94 "Short-Term Rentals" to require owners of Short-Term Rentals to obtain a Short-Term Rental permit." This Local Law preserves and protects the health, character, safety and general welfare of the residential neighborhoods and rural areas where Short-Term Rentals are operated and to mitigate the adverse effects of Short-Term Rentals.

Copies of the proposed law, sponsored by Councilmember Lucachik, are on file in the Town Clerk's Office, Monday through Friday, from 9:00 a.m. to 4:00 p.m.

Supervisor Keding stated the floor is open, anyone that would like to speak in regard to the local law.

There were no comments from the public.

Supervisor Keding stated the public hearing is closed.

There was a second public hearing scheduled for this evening, that has been cancelled. The applicant had sent correspondence to the Town hall today requesting the removal of their special use permit application for live entertainment for Foxhole Farm Winery, 8325 Cole Road.

One piece of correspondence was received from Jean Shanahan, regarding Foxhole Farm Winery, that is on file in the Code Enforcement office.

Regular business:

A motion was made by Councilwoman Lucachik and was seconded by Councilwoman Martin to approve the minutes of the January 17, 2024 regular meeting.

Supervisor Keding	Yes	Councilman Cartechine	Yes
Councilwoman Lucachik	Yes	Councilwoman Martin	Yes
Councilwoman Selby	Yes		

COPY

Motion Con't:

five (5) Yes Carried

A motion was made by Councilman Cartechine and was seconded by Councilwoman Selby upon review by the Town Board, that fund bills in the amount of \$215,444.79 be paid.

Supervisor Keding	Yes	Councilman Cartechine	Yes
Councilwoman Lucachik	Yes	Councilwoman Martin	Yes
Councilwoman Selby	Yes		

five (5) Yes Carried

Supervisor Keding stated the following has been received and filed under correspondence:

- NYSEG Completes State's Future Grid Challenge Press Release
- 2024 Annual DCO/ACO Conference Information
- Dog Control Officer Report for January 2024
- Letter from Buffalo Niagara Partnership & 2024 Advocacy Agenda
- Association of Towns presentation of 2024-2025 Executive Budget
- Code Enforcement Office Monthly Reports for 2023
- Letter from Erie County Department of Environment and Planning - Erie County Community Climate Action Plan (CCAP)
- Draft minutes from NEST January 2024 meeting
- Erie County Sewer District No. 3, Board of Managers meeting minutes January 31, 2024

New business:

Supervisor Keding stated the floor is open for public comment.

The following persons were heard:

- Jeff Persanti
- Richard Bohrer
- Jean Shanahan

Supervisor Keding stated the floor is closed.

A motion was made by Councilwoman Lucachik and was seconded by Councilwoman Martin,

COPY

REGULAR BOARD MEETING  
FEBRUARY 7, 2024

TOWN HALL  
7:30 P.M.

WHEREAS, a resolution was duly adopted by the Town Board of the Town of Boston for a public hearing to be held by said Town Board on February 7, 2024 at 7:35 p.m. at Boston Town Hall, 8500 Boston State Road, Boston, New York, to hear all interested parties on a proposed Local Law entitled "A LOCAL LAW To amend the Boston Town Code to add Chapter 94, Short-Term Rentals, to require owners of Short-Term Rentals to obtain a Short-Term Rental permit;" and

WHEREAS, notice of said public hearing was duly advertised in the Springville Journal, the official newspaper of said Town, on January 18, 2024; and

WHEREAS, said public hearing was duly held on February 7, 2024 at 7:35 p.m. at Boston Town Hall, and all parties in attendance were permitted an opportunity to speak on behalf of or in opposition to said Proposed Local Law, or any part thereof; and

WHEREAS, the Boston Town Board, after due deliberation, finds it in the best interest of the Town of Boston to adopt said Local Law;

NOW, THEREFORE, BE IT RESOLVED, that the Town Board of the Town of Boston hereby adopts said 2024 Local Law No. 1 entitled "A LOCAL LAW To amend the Boston Town Code to add Chapter 94, Short-Term Rentals, to require owners of Short-Term Rentals to obtain a Short-Term Rental permit;" a copy of which is attached hereto and made a part of this resolution, and be it

FURTHER RESOLVED, that the Town Clerk be and hereby is directed to enter said Local Law in the minutes of this meeting and in the Local Law Book of the Town of Boston, and to give due notice of the adoption of said Local Law to the Secretary of State of New York.

Supervisor Keding	Yes	Councilman Cartechine	Yes
Councilwoman Lucachik	Yes	Councilwoman Martin	Yes
Councilwoman Selby	Yes		

five (5) Yes

Carried

**LOCAL LAW TO BE ENACTED BY  
THE BOSTON TOWN BOARD  
TOWN OF BOSTON, NEW YORK**

**2024 LOCAL LAW NO. 1**

**A LOCAL LAW of the Town of Boston amending the Town Code of the Town of Boston to add Chapter 94 "Short-Term Rentals".**

**BE IT ENACTED BY THE TOWN BOARD OF THE TOWN OF BOSTON AS FOLLOWS:**

**A LOCAL LAW to amend the Boston Town Code to add Chapter 94, "Short-Term Rentals", to require owners of Short-Term Rentals to obtain a Short-Term Rental Permit"**



**Section 1. Title**

This local law shall be known as and may be cited as Local Law No. 1-2024 to amend the Boston Town Code to add Chapter 94 “Short-Term Rentals” requiring owners to obtain a Short-Term Rental permit from the Town of Boston in order to continue or commence operation of a Short-Term Rental.

**Section 2. Authorization**

The adoption of this Local Law is in accordance with Section 264 of New York Town Law and Chapter 10 of the New York Municipal Home Rule Law.

**Section 3. Legislative Intent and Purpose**

The Town of Boston recognizes that it would be beneficial for the Town to control and regulate the use of Short-Term Rentals within the Town of Boston. The provisions of this section are intended to preserve and protect the health, character, safety and general welfare of the residential neighborhoods and rural areas where Short-Term Rentals are operated and to mitigate the adverse effects of Short-Term Rentals.

**Section 4. Amendment**

The Boston Town Code shall be amended to add Chapter 94 “Short-Term Rentals” as follows:

**94.1 Definitions**

As used in this chapter, the following term shall have the meaning indicated:

Short-Term Rental - Any portion of real property having the required frontage on a public street per Section 123-122 and rented for compensation in exchange for lodging for a period of not more than 31 consecutive days. For the purpose of this Chapter, the term “Short-Term Rental” shall not include boarding/lodging houses, hotels, motels or ongoing month to month tenancies.

**94.2 Presumption of Dwelling Unit as Short-Term Rental Property**

A. The presence of the following shall create a presumption that all or part of the property is being used as a Short-Term Rental.

(1) All or a part of the property is offered for lease on a short-term rental website, including but not limited to Airbnb, Home Away and VRBO, for a rental period of less than 31 days and/or

(2) All or a part of the property is offered for lease for a period of 31 days or less through any form of advertising.

(3) Any indication of frequent change of residents and/or type and number of vehicles observed from month to month.

B. The foregoing presumptions may be rebutted by evidence presented to the Code

Enforcement Officer that the premises is not operated as a Short-Term Rental.

### **94.3 Required Permit**

- A. Owners shall not use their property as a Short-Term Rental without obtaining a revocable Short-Term Rental permit.
- B. A Short-Term Rental permit shall be valid for two (2) years and must be renewed 30 days prior to expiration of the current permit if the premises is to continue to operate as a Short-Term Rental.
- C. A Short-Term Rental permit is not transferable to a new owner. The new owner of the premises subject to a Short-Term Rental must file a new permit application.
- D. Notwithstanding the foregoing, those properties with Short-Term Rental commitments existing on the date this section takes effect shall be permitted to honor such existing commitments and continue to make commitments for Short-Term Rentals but must apply for a permit within 90 days of the Local Law's effective date for all future Short-Term Rental commitments. In the event such application is denied, all future commitments for rentals after the date the application is denied shall be cancelled.

### **94.4 Short-Term Rental Permit Application Requirements**

- A. Applications for a Short-Term Rental permit may be obtained at the Town of Boston Town Clerk's office. The Short-Term Rental permit shall be submitted to the Code Enforcement Officer, accompanied by payment of a nonrefundable permit fee to be determined from time to time by resolution of the Town Board. The application shall include the following:
  - (1) The signatures of all owners and their designated agents.
  - (2) A statement authorizing the Code Enforcement Officer to inspect the property to ensure compliance with all requirements and standards contained within this chapter.
  - (3) An acknowledgement of present and ongoing compliance with the Short-Term Rental standards as defined in this chapter including, but not limited to, the demonstration of adequate off-road parking spaces for the proposed Short-Term Rental.
  - (4) A list of each property owner and the name of any manager or management agency managing the property including name, address, telephone number and email address of each.
  - (5) The name, address, phone number and email address of the most local contact person who shall be responsible and authorized to act on the owner's behalf to promptly remedy any violation of the standards outlined in this section. The contact person may be an owner or an agent designated by the

owner to serve as a contact person and shall respond to any communication from the Town Code Enforcement Officer within 24 hours.

(6) An accurate suitable floor plan for each level of the dwelling that can be occupied measuring at least 8.5" X 11" drawn to scale and certified by the applicant. The floor plan does not need to be prepared by a professional, but must include the following:

- a. The location of buildings and required parking (at least 350 sq. ft. per parking space is required)
- b. The location of house utilities and all rooms including bedrooms, windows, exits and any heating/cooling units on each level of the dwelling that can be occupied.
- c. If an attic is to be occupied, the entire dwelling must be sprinkled.

(7) A statement that none of the owners of the subject property has had a Short-Term Rental permit revoked within the previous year for any rental properties owned individually or together with others.

(8) County Health Department approval of the property's septic system, if appropriate.

(9) Certification that the property's well has been tested or inspected by the New York State Health Department.

#### **94.5 Short-Term Rental Standards**

##### **A. Property Requirements**

- (1) Property must comply with and meet all current New York State Building Codes.
- (2) There shall be one (1) working smoke detector in each sleeping room and one (1) additional smoke detector on each floor. Smoke detectors shall be interconnected. Carbon monoxide detectors shall be installed as required by the New York State Fire Prevention and Building Code.
- (3) Evacuation procedures must be posted in each sleeping room to be followed in the event of a fire or smoke condition or upon activation of a fire or smoke-detecting or other alarm device.
- (4) There shall be an ABC fire extinguisher on each floor and in the kitchen. Fire extinguishers shall be inspected prior to a renter occupying the property and no less than monthly by the permit holder to ensure each contains a full charge. A record of the date inspected initialed by the permit holder shall be maintained and made available to the Code Enforcement Officer upon request.



- (5) The house number shall be located at the road and on the dwelling so that it is clearly visible from both the road and the driveway.
- (6) Exterior doors shall be operational and all passageways to exterior doors shall be clear and unobstructed.
- (7) Electrical systems shall be in good operating condition, labeled, unobstructed and visible for the Code Enforcement Officer during the permitting process. Any defects found shall be corrected prior to permit issuance.
- (8) All fireplaces shall comply with all applicable laws and regulations.
- (9) The property must have a minimum of one (1) off-street parking space for every bedroom shown on the floor plan included with the application. No parking on the street is permitted.
- (10) Maximum occupancy for each Short-Term Rental unit shall not exceed two (2) people per bedroom shown on the floor plan included with the application. The Maximum occupancy of the Short-Term Rental unit shall not exceed eight (8) people including permanent residents and renters.
- (11) If the property has a septic system, the maximum occupancy shall be defined by the capabilities of the septic system but in no event shall overnight occupancy for a Short-Term Rental unit exceed eight (8) people total.

B. Insurance Standards

All applicants and permit holders must provide Evidence of Property insurance and a Certificate of Liability insurance indicating that the premises is rated as a Short-Term Rental and maintain such insurance throughout the term of the Short-Term Rental permit.

C. Rental Contract. All applicants and permit holders must have a rental contract that includes the following:

- (1) Maximum property occupancy
- (2) Maximum on-site parking provided
- (3) Good Neighbor Statement stating:
  - a. The Short-Term Rental is in a residential area in the Town of Boston and renters should be considerate of the residents in neighboring homes.
  - b. Quiet hours are between 11:00 PM and 8:00 AM.
  - c. All guests will be subject to New York Penal Law Section 240.20 or any successor statute regarding disorderly conduct.
  - d. Littering is illegal.

**94.6 Procedure Upon Filing Application**

- A. Short-Term Rental permit applications shall be filed with the Town of Boston Code Enforcement Officer with all supporting documentation and the nonrefundable permit fee. Only completed applications will be accepted. The Code Enforcement Officer may decline to accept an application for consideration for any of the following reasons:
- (1) The application or documentation required by this Section was not included or the full permit fee was not paid.
  - (2) A previously issued Short-Term Rental permit was revoked within the past year and defects and/or violations have not been corrected and inspected by the Code Enforcement Officer.
- B. Upon receipt of a completed Short-Term Rental permit application, property owners within 100 feet of all property lines of the subject parcel will be notified of the application by the Town of Boston and given the opportunity to comment.
- C. Upon the Code Enforcement Officer's acceptance of the completed permit application, all documents and information required by this Section and the permit fee, the Code Enforcement Officer shall have 30 days to conduct a property inspection to certify that all Short-Term Rental requirements have been met.
- D. Upon approval of the Short-Term Rental application by the Code Enforcement Officer, a Short-Term Rental permit will be issued. Short-Term Rental permits issued pursuant to this Section shall state the following:
- (1) The name, address, phone number and email address of each person or entity that has an ownership interest in the Short-Term Rental property.
  - (2) The name, address, phone number and email address of the primary contact person who shall be available during the entire time the Short-Term Rental is being rented.
  - (3) The maximum occupancy and vehicle limits for the Short-Term Rental property.
  - (4) Identification of the number and location of available parking spaces.
  - (5) Any conditions imposed by the Board of Zoning Appeals and/or the Code Enforcement Official.

**94.7 Conformity and Display of Permit**

- A. Short-Term Rental permits are subject to continued compliance with the requirement of these regulations.
- (1) If the Code Enforcement Officer has probable cause to believe that the homeowner is not in compliance with the provisions of this Law, he may



conduct an inspection of the Short-Term Rental property for purposes of ensuring compliance with this Section. If the property owner refuses to permit the Code Enforcement Officer to inspect the property, the permit will be revoked. If an inspection authorized herein is conducted, the Code Enforcement Officer shall use the results of such inspection in determining whether to revoke the permit.

- (2) The Short-Term Rental permit, maximum occupancy limit, maximum parking, contact form and standards shall be prominently displayed inside and near the front entrance of the Short-Term Rental.
- (3) The Short-Term Rental permit holder shall ensure that current and accurate information is provided to the Code Enforcement Officer and that he or she notifies the Code Enforcement Officer immediately of any change in the information displayed on the permit. If, based upon such changes, the Code Enforcement Officer issues an amended Short-Term Rental permit, the owner must immediately post the amended permit inside and near the front entrance of the Short-Term Rental.
- (4) The Short-Term Rental permit holder must conspicuously display the Short-Term Rental permit number in all advertisements for the applicable Short-Term Rental.

#### **94.8 Compliance and Penalties**

- A. Violations of this Section or of any Short-Term Rental permit issued pursuant to this Section shall be subject to enforcement and penalties prescribed in this Section.
- B. If the Code Enforcement Officer either witnesses or receives a written complaint of an alleged violation of this Section or of any Short-Term Rental permit issued pursuant to this Section, the Code Enforcement Officer shall properly record such complaint and immediately investigate the report thereon. If the Code Enforcement Officer determines there is a violation of this Law, the owners and/or agent(s) shall be notified in writing of said violations and the Code Enforcement Officer may take any or all of the following actions:
  - (1) Attach conditions to the existing Short-Term Rental permit.
  - (2) Suspend the Short-Term Rental permit. The Notice of Suspension shall be provided to the property owner and a copy filed with the Town Clerk.
  - (3) Require corrective action that remedies the violation(s). The corrective action must be completed and approved within 30 days of notice from the Code Enforcement Officer or the owner risks revocation of the permit.
  - (4) Issue a court appearance ticket for violation of a Town law.

- (5) Revoke the Short-Term Rental permit. In this event, the building shall be posted as such. Should a permit be revoked, all owners of the Short-Term Rental are prohibited from obtaining a Short-Term Rental permit on the property for one (1) year after the date of revocation. The Code Enforcement Officer shall send the Notice of Revocation to the property owners and shall file a copy with the Town Clerk.

**94.9 Application for Renewal of Permit. Renewal permits will be granted for an additional two-year term if the following conditions are met:**

- A. Applications for renewal shall be made 30 days prior to expiration of the current permit and require payment of a renewal fee.
- B. At the time of application for renewal, the owner must present the previous permit for Short-Term Rental.
- C. The property must have undergone an inspection performed by the Code Enforcement Officer.
- D. Any violations must be remedied prior to renewal of a Short-Term Rental permit.
- E. If a Short-Term Rental permit holder fails to apply for renewal of the permit by the time it expires, a new Short-Term Rental permit must be obtained.

**94.10 Grounds for Suspension or Revocation of Permit**

- A. The Code Enforcement Officer may immediately suspend a Short-Term Rental permit based on any of the following grounds:
  - (1) Applicant has falsified or failed to provide information in the application for a permit or the application for permit renewal.
  - (2) Applicant failed to meet or comply with any of the requirements of this Chapter.
  - (3) Owner is in violation of any provisions of the Code of the Town of Boston.
  - (4) Owner has violated any provision of the Penal Code of the State of New York that occurred at or was related to the occupancy of the Short-Term Rental.
  - (5) Any conduct on the premises that disturbs the health, safety, peace or comfort of the neighborhood or that otherwise creates a public nuisance.

**94.11 Appeals and Hearings**

The property owner is entitled to appeal the Code Enforcement Officer's determination to the Town Board when his or her application for a Short-Term Rental permit or a Short-Term Rental permit renewal is denied or a Short-Term Rental permit is revoked. A Notice of Appeal shall be filed with the Town Clerk and the Town Board within 60 days of the Code Enforcement



Officer's filing of the denial or revocation with the Town Clerk. A public hearing shall be held by the Town Board not more than 45 days after the filing of the Notice of Appeal.

**Section 5. Validity and Severability**

Should any word, section, clause, paragraph, sentence, part of provision of this Local Law be declared invalid by a Court of competent jurisdiction, such determination shall not affect the validity of any other part hereof.

**Section 6. Repeal, Amendment and Supersession of Other Laws**

All other ordinances or local laws of the Town of Boston that are in conflict with the provisions of this local law are hereby superseded or repealed to the extent necessary to give this local law force and effect during its effective period.

**Section 7. Effective Date**

This Local Law will take effect upon filing in the office of the New York State Secretary of State.

A motion was made by Councilwoman Selby and was seconded by Councilman Cartechine,

**RESOLUTION 2024-20**

**AUTHORIZING PAYMENT AND BUDGET  
AMENDMENT FOR REPLACEMENT OF EAST HILL  
PUMPING STATION VARIABLE FREQUENCY DRIVES**

WHEREAS, the Town of Boston ("Town") and Erie County Water Authority ("ECWA") are parties to a Lease Management Agreement pursuant to which ECWA manages the Town's water distribution system and related sales and distribution of water to customers in Town water districts; and

WHEREAS, ECWA alerted the Town that on November 22, 2022, one of the two variable frequency drives ("VFDs") at the East Hill Pumping Station on Cole Road failed; and

WHEREAS, there are two pumps at the East Hill Pumping Station, and without a functional VFD there would be no automatic emergency backup should the remaining pump that has a functional VFD fail; and

WHEREAS, the VFDs on both pumps were of the same vintage and considered obsolete, and in a memorandum dated December 7, 2022 ECWA recommended that the Town replace both VFDs as well as the VFD controls, which although more costly than replacement of just the one VFD which had failed was recommended to improve operational control, reduce maintenance, and extend the life of the replacement VFDs; and

WHEREAS, Town Engineer Clark Patterson Lee reviewed the options presented by ECWA and concurred with the recommendation to replace both VFDs and their controls; and

WHEREAS, in a December 2022 Resolution, the Town agreed to reimburse ECWA for the actual cost to perform the necessary work as per the terms of the

lease management agreement, and ECWA assumed responsibility for the procurement and installation of the replacement VFDs and controls, including following applicable procurement laws; and

WHEREAS, the VFD and control replacement work was completed in 2023, and the total amount now due to ECWA in an invoice dated November 28, 2023 is \$73,924.64; and

WHEREAS, this pump station services Water District 3 and subsequently the District 3 extension; and

WHEREAS, the adopted budget for the year ending December 31, 2023 did not include the full cost of this repair;

NOW THEREFORE BE IT RESOLVED, that the Town Supervisor hereby is authorized to pay to Erie County Water Authority the sum of \$73,924.64 for East Hill Pumping Station variable frequency drive upgrades, with said sum to be paid with the funds of Water District 3 and District 3 Extension allocated based on parcel count; and

FURTHER RESOLVED, that a budget amendment is authorized to appropriate an additional \$70,576 of fund balance in Water District 3 to account HC0-8340-0400 and \$1,165 of fund balance in Water District 3 Extension to account HF0-8340-0400.

Supervisor Keding	Yes	Councilman Cartechine	Yes
Councilwoman Lucachik	Yes	Councilwoman Martin	Yes
Councilwoman Selby	Yes		

five (5) Yes Carried

A motion was made by Councilman Cartechine and was seconded by Councilwoman Lucachik to approve new member of North Boston Volunteer Fire Company, Erik Filkorn.

Supervisor Keding	Yes	Councilman Cartechine	Yes
Councilwoman Lucachik	Yes	Councilwoman Martin	Yes
Councilwoman Selby	Yes		

five (5) Yes Carried

A motion was made by Councilwoman Selby and was seconded by Supervisor Keding to approve applications for annual refuse licenses: MRC Disposal Inc., Modern Disposal Services, Inc, and Waste Management of NY, LLC.

Supervisor Keding	Yes	Councilman Cartechine	Yes
Councilwoman Lucachik	Yes	Councilwoman Martin	Yes
Councilwoman Selby	Yes		

five (5) Yes Carried



A motion was made by Councilwoman Martin and was seconded by Councilwoman Selby to approve the Use of Facility application from Boston Democratic Social Club, for Easter Egg Hunt, March 30, 2024, 10:00 am to 4:00 pm, Community room with kitchen, bathroom facilities, and Town fields.

Supervisor Keding	Yes	Councilman Cartechine	Yes
Councilwoman Lucachik	Yes	Councilwoman Martin	Yes
Councilwoman Selby	Yes		

five (5) Yes Carried

A motion was made by Councilwoman Martin and was seconded by Supervisor Keding to approve the Use of Facility application from Conservation Advisory Council, for Snowshoe and Snowmen Event, February 17, 2024, 8:00 am to 3:00 pm, Community room with kitchen, and bathroom facilities.

Supervisor Keding	Yes	Councilman Cartechine	Yes
Councilwoman Lucachik	Yes	Councilwoman Martin	Yes
Councilwoman Selby	Yes		

five (5) Yes Carried

Old business:

A motion was made by Supervisor Keding and was seconded by Councilwoman Martin to appoint Donnalyn Nuernberger as part-time Assessment Clerk, \$19.92 per hour.

Supervisor Keding	Yes	Councilman Cartechine	Yes
Councilwoman Lucachik	Yes	Councilwoman Martin	Yes
Councilwoman Selby	Yes		

five (5) Yes Carried

Reports and Presentations:

Highway Superintendent Telaak reported on the following:

Highway department will be around cleaning out ditches. If any residents that live on Town roads and would like their ditch cleaned out, give us a call. In the subdivisions we don't clean out too many ditches because people don't like their ditches cleaned out. We will be around doing clean up from plow damage. If there is any damage to your lawn, we do clean that up too. This past week we had our first pothole show up on Shero Road. It was about six inches in diameter. I took like one shovel of a cold patch to fix. When I first started, the roads were in poor condition, we used to get truckloads of cold patch. There are a lot of Christmas trees still out by the road. They need to be picked up by Waste Management not the highway department. Brush-pick up will begin on April 1<sup>st</sup>, if we get paid for our brush pickup from last year, which we have not got totally paid for, hopefully that will be taken care of before April 1<sup>st</sup>.

Councilwoman Selby reported on the following:

Thanked the Town Clerk's office for working with me and Jared Blake from Waste Management on some issues that we have had lately. Waste Management was very responsive and compromising in helping those people where there were some safety issues with garbage on a certain road in the Town, I think we got it resolved. I don't see anybody from that road here tonight, so I guess it is good.

Councilman Cartechine reported on the following:

Thanked the North Boston Fire Company for the invitation to their installation dinner where we installed their officers for the new year. It was a really nice evening. Thanked the Boston Fire Company for the invitation for their installation dinner this past Saturday. Installed the new officers and have a meal. It was a nice evening as well. I have the blood drive numbers. We set a record yesterday, the ConnectLife blood drive here in Town, we collected 108 units of blood. Which is a big record for this local blood drive. I knew it was big because I donated, and I've never seen it as busy as it was yesterday. The ConnectLife group really do a nice job, we are grateful to have them here. Good job to everybody who participated.

Councilwoman Lucachik reported on the following:

We had a question regarding the fee for a short-term rental. That could have been brought up during the public hearing. We really cannot set up a fee until we know what you are asking for, that is what the number of pages in the law provides. What are we setting up, what are we asking for? If I were to rent out my location, my house, I would want my neighbors to feel comfortable that it has been vetted by professionals. This is what this law is for. If we heard anything from the public hearing that needed to be revisited, then we would have held off and tabled this item. We didn't hear anything, so we continued. The next step is to address the fees and usually they are not extravagant. The permit will be good for two years. The Planning Board is scheduled to meet on the second Tuesday, February 13<sup>th</sup>.

Councilwoman Martin reported on the following:

Great job Jen on that local law, is a very important law. I was witness to a Town that did not have a local law in place. There was a short-term rental next to the rental we were at. A fire started because there was a barbecue grill on the wood deck, the whole house burned down, putting other properties in jeopardy. A lot of people are doing that now, VRBO and Airbnb, great job being proactive. The Conservation Advisory Council always puts a lot of effort into the Snowshoe and Snowmen event. It is a free event for families. They pass out snowshoes and we are supposed to get some snow next week. Hopefully there will be enough snow that families come out on February 17<sup>th</sup>.



COPY

Town Clerk Quinlan reported on the following:

Thanked the Boston Emergency Squad for the invitation to their installation dinner, it was an honor to attend. My office is in the process of preparing the 2024 Town and County tax bills to be mailed next week, mid-February. At that time tax bills will be available on the Town of Boston website. Payments may be made by mail, in person, and online. Credit card is accepted for online payments. Tax payments are due March 15<sup>th</sup>.

Supervisor Keding reported on the following:

Next Town Board meeting scheduled for February 21<sup>st</sup> will be cancelled due to a lack of quorum. It is a Winter break for some of us that have children in school, and they will be enjoying time with their families. At that time, I will be at the Association of Towns annual conference in New York City. Our next regularly scheduled meeting will be March 6<sup>th</sup>.

I did ask Allison in my office to put it out there on the Town's social media that Erie County is doing some improvements up at the Boston Forest County Park. We do have a county park here in the Town of Boston. They are putting in drainage and widening the parking lot, it has been a mud pit for years. It will be a nice amenity for our community.

One of the other things that is coming from Erie County Senior Services. The community room is where the congregate dining lunch program is. We do have a kitchen for those of you if you are not aware. We do have some appliances that have been there probably since the day that the kitchen was originally operational. Erie County has come up with some additional funds and they are reaching out to communities across Erie County. Boston being one of them and we are looking at potentially getting funding for a new subzero refrigerator and a new range, and potentially a new dish washing machine. It will be a nice amenity as that congregate lunch dining program grows. There has been kind of an increasing demand or ask of would the Town of Boston consider getting into an evening dining program, that's for the Town Board to decide how we want to move forward with that. The next Comprehensive Plan meeting is next Monday February 12<sup>th</sup>, in the community room for the Comprehensive Plan committee members.

These members are residents of our community. Tomorrow, myself, my assistant, some of the team from CPL, as well as one of the consultants, we will be going to Hamburg Schools doing outreach with the participant in government teachers and doing a survey to identify what the younger generation wants in the community of Boston.

Thanked the Board for allowing me to attend the Association of Towns annual conference. Code enforcement is a hot topic these days and there will be a lot weighing heavy on that this year.

Highway Superintendent, the Town Board will look at the documentation supplied, the Town Board, all five of us, makes the decision to amend the budget if we want to go over the budgeted amount for additional funds to appropriate additional taxpayer money for services.

REGULAR BOARD MEETING  
FEBRUARY 7, 2024

COPY

TOWN HALL  
7:30 P.M.

A motion was made by Supervisor Keding and was seconded by Councilman Cartechine to adjourn the meeting at 8:18 p.m.

Supervisor Keding	Yes	Councilman Cartechine	Yes
Councilwoman Lucachik	Yes	Councilwoman Martin	Yes
Councilwoman Selby	Yes		

five (5) Yes

Carried

-----  
SANDRA L. QUINLAN, BOSTON TOWN CLERK



# TOWN CLERK'S MONTHLY REPORT

TOWN OF BOSTON, NEW YORK

JANUARY, 2024

TO THE SUPERVISOR:

PAGE 1

Pursuant to Section 27, Subd 1 of the Town Law, I hereby make the following statement of all fees and moneys received by me in connection with my office during the month stated above, excepting only such fees and moneys the application and payment of which are otherwise provided for by Law:

## A1255

<u>1</u>	DECALS	<u>1.38</u>
<u>1</u>	MARRIAGE LICENSES NO. 24001 TO 24001	<u>17.50</u>
<u>19</u>	PHOTOCOPIES	<u>4.75</u>
<u>4</u>	DEATH CERTIFICATES	<u>40.00</u>
<u>13</u>	FAXES	<u>3.25</u>

**TOTAL TOWN CLERK FEES**

**66.88**

## A2025

<u>1</u>	USE OF FACILITY FEES	<u>75.00</u>
<u>3</u>	USE OF SPORTING FACILITY	<u>750.00</u>

**TOTAL A2025**

**825.00**

## A2110

<u>1</u>	VARIANCE	<u>200.00</u>
----------	----------	---------------

**TOTAL A2110**

**200.00**

## A2530

<u>1</u>	GAMES OF CHANCE PROCEEDS	<u>260.55</u>
----------	--------------------------	---------------

**TOTAL A2530**

**260.55**

## A2544

<u>49</u>	DOG LICENSES	<u>422.00</u>
-----------	--------------	---------------

**TOTAL A2544**

**422.00**

## A2555

<u>11</u>	BUILDING PERMITS	<u>530.00</u>
<u>1</u>	PLANNING BD SUB DIV REV	<u>400.00</u>
<u>2</u>	PUBLIC HEARING FEE	<u>200.00</u>

**TOTAL A2555**

**1,130.00**

## A2590

<u>1</u>	SPECIAL PERMIT	<u>25.00</u>
----------	----------------	--------------

**TOTAL A2590**

**25.00**

## SR2130

<u>8</u>	WM BAG STICKER	<u>24.00</u>
----------	----------------	--------------

**TOTAL SR2130**

**24.00**

**TOWN CLERK'S MONTHLY REPORT**

JANUARY, 2024

page 2

**DISBURSEMENTS**

PAID TO SUPERVISOR FOR GENERAL FUND	<u>2,929.43</u>
PAID TO SUPERVISOR FOR REFUSE & GARBAGE	<u>24.00</u>
PAID TO NYSDEC FOR DECALS	<u>23.62</u>
PAID TO NYS ANIMAL POPULATION CONTROL PROGRAM	<u>66.00</u>
PAID TO NYS HEALTH DEPT FOR MARRIAGE LICENSES	<u>22.50</u>
<b>TOTAL DISBURSEMENTS</b>	<b><u>3,065.55</u></b>

0. \*

2,929.43 +

24.00 +

2,953.43 \*\*

FEBRUARY 1, 2024

  
 \_\_\_\_\_, SUPERVISOR  
 JASON KEDING FEB 6<sup>th</sup> 2024

**STATE OF NEW YORK, COUNTY OF ERIE, TOWN OF BOSTON**

I, SANDRA QUINLAN, being duly sworn, says that I am the Clerk of the TOWN OF BOSTON that the foregoing is a full and true statement of all Fees and moneys received by me during the month above stated, excepting only such Fees the application and payment of which are otherwise provided for by law.

Subscribed and sworn to before me this

  
 \_\_\_\_\_  
 Town Clerk

5<sup>th</sup> day of February 2024

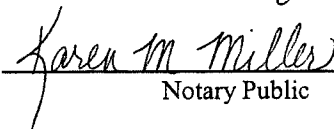
  
 \_\_\_\_\_  
 Notary Public

KAREN M. MILLER  
 Notary Public, State of New York  
 Reg. No. 01MI6385215  
 Qualified in Erie County  
 Commission Expires 12-31-2026

# **NYSEG and RG&E Remind Customers of Resources to Manage Energy Bills**

*Customers can take control of their energy costs this winter*

*The Companies remind customers of options on its websites that can help manage energy bills*

**BINGHAMTON, N.Y. — February 7, 2024 —** New York State Electric & Gas (NYSEG) and Rochester Gas and Electric (RG&E) are reminding customers of available resources to help manage their energy bills. The Companies build and maintain a safe, reliable system to deliver electricity or natural gas to your home or business.

New York State opened the State’s electric and natural gas industries to competition in the 1990s. Changes in the markets provided an opportunity for consumers to choose who provides their energy supply; either their utility or a third-party supplier known as an Energy Services Company or ESCO.

Customers can purchase energy supply from the utility or choose another energy supplier. A customer’s delivery charges, made up of a basic service charge, delivery charge, transition charge, and other surcharges are billed by NYSEG or RG&E regardless of a customer’s energy supplier. These charges are what customers pay NYSEG or RG&E to transport energy.

A customer’s supply charges, made up of a variable supply and a merchant function charge, is what customers pay to their energy supplier for the energy they use. NYSEG and RG&E’s supply prices are variable based on market prices and passed through to customers without profit or markup. Some suppliers may offer a fixed price.

“It’s important to note that the price of electricity and natural gas change each month, as market prices fluctuate,” said Senior Director of NY Energy Services for NYSEG and RG&E, Pat Fox. “Part of NYSEG and RG&E’s commitment to our customers is ensuring we are always there for them by informing them of their options so they can make the best choice for their households or businesses.”

Customers can go to [dps.ny.gov](https://dps.ny.gov) and select Power to Choose – Energy Competition under tools to find available supplier pricing by zip code.

There may also be community choice energy programs that customers are auto enrolled in by their municipality. To learn more about those programs and how they work, visit: [Community Choice Aggregation | Department of Public Service \(ny.gov\)](https://www.dps.ny.gov/energy-choice)

There are a number of additional resources that can help customers understand and manage their monthly bills. The companies offer energy-saving tips and programs that can help lower energy use and control costs, as well as payment plans and assistance programs to manage energy costs. Budget

Billing can help spread seasonal energy costs from cooling or heating evenly over 12 months. While it's not a savings plan and is adjusted based on customer's energy use, it can help customers balance their bills throughout the year. Customers can learn more by visiting [nyseg.com/UnderstandYourUsage](https://nyseg.com/UnderstandYourUsage) or [rge.com/UnderstandYourUsage](https://rge.com/UnderstandYourUsage).

###

---

**About NYSEG:** New York State Electric & Gas Corporation (NYSEG) is a subsidiary of Avangrid, Inc. Established in 1852, NYSEG operates approximately 35,000 miles of electric distribution lines and 4,500 miles of electric transmission lines across more than 40% of upstate New York. It also operates more than 8,150 miles of natural gas distribution pipelines and 20 miles of gas transmission pipelines. It serves approximately 894,000 electricity customers and 266,000 natural gas customers. For more information, visit [www.nyseg.com](https://www.nyseg.com).

**About RG&E:** Rochester Gas and Electric Corporation (RG&E) is a subsidiary of Avangrid, Inc. Established in 1848, RG&E operates approximately 8,800 miles of electric distribution lines and 1,100 miles of electric transmission lines. It also operates approximately 10,600 miles of natural gas distribution pipelines and 105 miles of gas transmission pipelines. It serves approximately 378,500 electricity customers and 313,000 natural gas customers in a nine-county region in New York surrounding the City of Rochester. For more information, visit [www.rge.com](https://www.rge.com).

**About Avangrid:** Avangrid, Inc. (NYSE: AGR) aspires to be the leading sustainable energy company in the United States. Headquartered in Orange, CT with approximately \$41 billion in assets and operations in 24 U.S. states, Avangrid has two primary lines of business: networks and renewables. Through its networks business, Avangrid owns and operates eight electric and natural gas utilities, serving more than 3.3 million customers in New York and New England. Through its renewables business, Avangrid owns and operates a portfolio of renewable energy generation facilities across the United States. Avangrid employs more than 7,500 people and has been recognized by JUST Capital in 2021, 2022, 2023 and 2024 as one of the JUST 100 companies – a ranking of America's best corporate citizens. In 2024, Avangrid ranked first among utilities and 12 overall. The company supports the U.N.'s Sustainable Development Goals and was named among the World's Most Ethical Companies in 2023 for the fifth consecutive year by the Ethisphere Institute. Avangrid is a member of the group of companies controlled by Iberdrola, S.A. For more information, visit [www.avangrid.com](https://www.avangrid.com).



#1 IN UTILITIES

CNBC 2024

---

**Media Contact:**

Alexis Arnold

[Alexis.arnold@avangrid.com](mailto:Alexis.arnold@avangrid.com)

585.953.3159

FOR IMMEDIATE RELEASE

February 14, 2024



## **Avangrid Subsidiaries NYSEG and RG&E Deliver Best Reliability in Five Years**

*In 2023, Companies saw year-over-year improvements in outage frequency and duration*

*More than \$320 million in infrastructure investments planned across the state this year to continue this trend*

**BINGHAMTON, N.Y. — February 14, 2024** —New York State Electric & Gas (NYSEG) and Rochester Gas and Electric (RG&E) subsidiaries of Avangrid, Inc. (NYSE: AGR), a leading sustainable energy company and member of the Iberdrola Group, today announced their best reliability in five years. Delivering energy safely and reliably to their 1.9 million customers is the top priority for NYSEG and RG&E. As the electric and gas infrastructure in Upstate New York ages, the Companies invest in the grid via reliability projects and upgrades to realize this objective. In 2023, both NYSEG and RG&E delivered their best reliability results in the last five years, with significant year-over-year improvements. This critical work will continue, particularly due to the size and scope of resiliency work needed to support growing dependency on electricity.

“With the increasingly intense and frequent storms in our region and growing electric demand, our customers deserve continued resiliency and improved reliability, and the \$5.2 billion of investments approved in our latest rate case enable that forward momentum,” said Pedro Azagra, CEO of Avangrid. “Enabling New York to have more reliable power, shorter or avoided outages, and new smart meter technology helps customers manage their energy costs; we will continue to invest to improve even more.”

The New York Public Service Commission sets reliability targets for its utilities in the form of System Average Interruption Frequency Index (SAIFI) and Customer Average Interruption Duration Index (CAIDI) metrics. These require the Companies to meet targets for both how often outages happen as well as the duration of those outages.

In 2024, NYSEG and RG&E will invest \$38 million in resiliency projects which include rebuilding circuits in Brewster, Elmira, Lancaster, Liberty, Oneonta and Rochester Central; \$35 million in automation, which add an additional 294 locations where they can remotely control equipment from the Energy Control Center; and more than \$250 million on replacing aging substation and overhead line equipment.

NYSEG and RG&E will also replace 45,000 aging electrical poles statewide, resume tree trimming on a regular cycle in NYSEG territory, and continue with non-pipes and non-wires alternatives to traditional upgrades.

When a customer's power is out, restoration can't come soon enough, but NYSEG and RG&E are taking the steps necessary to modernize the grid to provide the safe, reliable service that's vital to our way of life. These results prove that investing in the electric infrastructure is the key to provide customers with the power they need, when they need it; this is a responsibility the Companies take seriously.

###

---

**About Avangrid:** Avangrid, Inc. (NYSE: AGR) aspires to be the leading sustainable energy company in the United States. Headquartered in Orange, CT with approximately \$41 billion in assets and operations in 24 U.S. states, Avangrid has two primary lines of business: networks and renewables. Through its networks business, Avangrid owns and operates eight electric and natural gas utilities, serving more than 3.3 million customers in New York and New England. Through its renewables business, Avangrid owns and operates a portfolio of renewable energy generation facilities across the United States. Avangrid employs more than 7,500 people and has been recognized by JUST Capital in 2021, 2022, 2023 and 2024 as one of the JUST 100 companies – a ranking of America's best corporate citizens. In 2024, Avangrid ranked first among utilities and 12 overall. The company supports the U.N.'s Sustainable Development Goals and was named among the World's Most Ethical Companies in 2023 for the fifth consecutive year by the Ethisphere Institute. Avangrid is a member of the group of companies controlled by Iberdrola, S.A. For more information, visit [www.avangrid.com](http://www.avangrid.com).



#1 IN UTILITIES

by CNBC 2024

---

**Media Contact:**

Shelby Cohen

Shelby.cohen@avangrid.com

607-788-6785

# **NYSEG and RG&E Preparing for Widespread Wind Event Expected to Impact State**

*Storm has potential to impact all the Companies' service areas*

*Crews are located throughout the state, ready to respond*

**BINGHAMTON, N.Y. — February 28, 2024, 7:00 a.m. —** New York State Electric & Gas (NYSEG) and Rochester Gas and Electric (RG&E) are preparing for a windstorm. The widespread wind event is expected to impact New York State Wednesday afternoon into Thursday. This storm has the potential to impact all of NYSEG and RG&E's service areas, which includes Western New York, Rochester, Finger Lakes, Southern Tier, North Country, Capital Region, Hudson Valley, and Westchester regions.

Current forecasts call for wind gusts up to 60 mph. The impact has the potential to bring down trees and limbs, causing damage to overhead power lines and other electrical equipment. As a result of the forecast the Companies have 200-line crews and 100 tree crew personnel placed throughout the state, ready to respond.

The Companies urge customers to monitor local forecasts and prepare for the possibility of service interruptions. The Companies' storm readiness teams have been monitoring weather forecasts, planning, readying crews and equipment, mobilizing employees for storm duty, and have contract tree and line crews ready to help restore service should outages occur.

## **Company Preparations**

### Readying Crews

In preparation for the event, the Company has pre-staged an additional 138 tree crew and 1,033-line personnel across the state to assist with restoration efforts if needed. Company and contractor crews will be onsite and prepared to facilitate an effective and efficient response should outages occur.

### Equipment Summary

The line and tree crews will be prepared to respond to any snow, ice, or wind related issues with bucket trucks, auger trucks, woodchippers, dump trucks, and backhoes.

### How to Stay Up to Date

NYSEG and RG&E will provide updates throughout the event to the general public on their website and social media channels (Facebook and X). Customers should also sign up for email alerts and download the NYSEG or RG&E mobile app to get the most up-to-date information.

### Safety Tips

The companies also offer customers the following reminders to prepare for the storm and stay safe if power outages do occur.

#### Before a storm strikes:

- You can use our mobile apps to report and check the status of outages. To download the application, customers should search “AVANGRID” in the Apple or Android app stores and select “NYSEG” or “RG&E”. The application is free to download.
- Sign up for Outage Alerts to receive updates automatically by phone, text, or email as the companies update the status of the restoration process in their area. Customers can sign up for outage alerts by visiting [here for NYSEG](#) and [here for RG&E](#).
- Keep battery-operated flashlights and radios on hand, along with supplies of drinking water and non-perishable foods.
- Make sure that smart phones, tablets, and other mobile devices are fully charged.
- Fill your car’s fuel tank.

#### Stay Away from Downed Wires:

- Stay at least 30 feet from a downed power line.
- If a downed wire comes in contact with your vehicle, stay inside and wait for help. If you must get out because of fire or other danger, jump clear of the vehicle to avoid any contact with the vehicle and the ground at the same time. Land with your feet together and hop with feet together or shuffle away; don’t run or stride.
- **NYSEG customers should call 1.800.572.1131 and RG&E customers should call 1.800.743.1701** to report downed power lines or other hazardous situations.

#### During a Power Interruption:

- Contact neighbors to see if their power is off. A loss of power may be the result of a blown fuse or a tripped circuit breaker.
- To report a power interruption, contact NYSEG at 1.800.572.1131 or RG&E at 1.800.743.1701.
- Keep refrigerators and freezers closed as much as possible. Most food will last 24 hours if you minimize the opening of refrigerator and freezer doors.

#### Power Restoration Priorities:

The Companies’ first priorities are to respond to reports of downed power lines to keep the public safe. **NYSEG customers are asked to call 1.800.572.1131 and RG&E customers are asked to call at 1.800.743.1701** to report downed wires. Once this vital public safety work is complete, the company will:

- Assess the damage to the electricity delivery system.
- Develop a detailed restoration plan.
- Make repairs as quickly as possible.



For additional information, including storm preparation tips, storm safety information, generator safety information, restoration priorities and emergency resources, visit Outage Central at [NYSEG.com](https://www.nyseg.com) or [RGE.com](https://www.rge.com) and on the Companies' social media pages:

- Facebook: @NYSEandG
- X: @NYSEandG
- Facebook: @RochGandE
- X: @RGandE

###

---

**About NYSEG:** New York State Electric & Gas Corporation (NYSEG) is a subsidiary of Avangrid, Inc. Established in 1852, NYSEG operates approximately 35,000 miles of electric distribution lines and 4,500 miles of electric transmission lines across more than 40% of upstate New York. It also operates more than 8,150 miles of natural gas distribution pipelines and 20 miles of gas transmission pipelines. It serves approximately 894,000 electricity customers and 266,000 natural gas customers. For more information, visit [www.nyseg.com](https://www.nyseg.com).

**About RG&E:** Rochester Gas and Electric Corporation (RG&E) is a subsidiary of Avangrid, Inc. Established in 1848, RG&E operates approximately 8,800 miles of electric distribution lines and 1,100 miles of electric transmission lines. It also operates approximately 10,600 miles of natural gas distribution pipelines and 105 miles of gas transmission pipelines. It serves approximately 378,500 electricity customers and 313,000 natural gas customers in a nine-county region in New York surrounding the City of Rochester. For more information, visit [www.rge.com](https://www.rge.com).

**About Avangrid:** Avangrid, Inc. (NYSE: AGR) aspires to be the leading sustainable energy company in the United States. Headquartered in Orange, CT with approximately \$44 billion in assets and operations in 24 U.S. states, Avangrid has two primary lines of business: networks and renewables. Through its networks business, Avangrid owns and operates eight electric and natural gas utilities, serving more than 3.3 million customers in New York and New England. Through its renewables business, Avangrid owns and operates a portfolio of renewable energy generation facilities across the United States. Avangrid employs more than 8,000 people and has been recognized by JUST Capital in 2021, 2022, 2023 and 2024 as one of the JUST 100 companies – a ranking of America's best corporate citizens. In 2024, Avangrid ranked first among utilities and 12 overall. The company supports the U.N.'s Sustainable Development Goals and was named among the World's Most Ethical Companies in 2023 for the fifth consecutive year by the Ethisphere Institute. Avangrid is a member of the group of companies controlled by Iberdrola, S.A. For more information, visit [www.avangrid.com](https://www.avangrid.com).



#1 IN UTILITIES

CNBC 2024

---

**Media Contact:**

Alexis Arnold

[alexis.arnold@avangrid.com](mailto:alexis.arnold@avangrid.com)

585.953.3159



# COUNTY OF ERIE

WILLIAM E. GEARY, JR.

COMMISSIONER

## DEPARTMENT OF PUBLIC WORKS

February 13, 2024

### CERTIFICATE AND NOTICE OF CLOSURE

STATE OF NEW YORK:

COUNTY OF ERIE: }SS

This is to certify that the Commissioner – Highways has jurisdiction of the highways of the County of Erie and does hereby restrict traffic patterns for that portion of the highway in the Town of Boston, said County, known as Erie, and described as follows:

#### Restriction:

The portion of Cole Rd (CR 442) located at 7076 Cole Rd, between Ward Rd and Old Lower East Hill Rd will have a single lane road restriction. Work will be performed February 19, between the hours of 7am to 10am, or until complete. This work is for the purpose of make ready work on electrical poles. Erie Net CDC will be performing the work.

A restriction is executed under Article V, Section 104A of the Highway Law in order to permit a proper completion of work of improvement thereon.

IN WITNESS WHEREOF: The undersigned has, on this 13<sup>th</sup> day of February, 2024, set his hand in Buffalo, New York.

Very truly yours,

A handwritten signature in blue ink, appearing to read "WEG", is written over a horizontal line.

WILLIAM E. GEARY, JR.  
COMMISSIONER OF PUBLIC WORKS

WEG/NAK

cc: See Attached List

February 13, 2024  
Cole Road Restriction  
Page 2

cc: William E Geary Jr., Commissioner of Public Works  
Karen Hoak, Deputy Commissioner of Highways  
Catherine C. Walsh, Special Assistant to the Commissioner  
Garrett Hacker, P.E.  
Darlene Svilokos, P.E.  
Jonathan DePlanche, P.E.  
Gina Wilkolaski, P.E.  
Karl Rohde, P.E.  
Rick Nendza  
Kaitlin Costello  
Kara Nicotra  
Lisa Chimera, Deputy County Executive  
Benjamin Swanekamp, Chief of Staff – Erie County Executive’s Office  
Jordan Zyglis, Legislative Liaison  
Jonathan McNulty, Legislature Senior Admin Clerk  
Daniel Meyer, Deputy Press Secretary for Erie County  
Daniel Neaverth, Dept. of Emergency Services  
Gregory Butcher, Dept. of Emergency Services  
Hon. John J Mills, Legislator, District 11  
Jason A Keding, Supervisor Town of Boston–supervisor@townofboston.com  
Robert Telaak, Town of Boston Highway superintendent–hwysuper@townofboston.com  
David Lilleck, Orchard Park Central School District Superintendent-  
Dlilleck@opschools.org  
Joseph Haier, Orchard Park Central School Transportation Supervisor-  
Jhaier@opschools.org  
Michael Pasnik, Aurora Maintenance District Engineer- Aurora@erie.gov  
Operators@NITTEC.org

**(Sent via e-mail)**



# COUNTY OF ERIE

WILLIAM E. GEARY, JR.

COMMISSIONER

## DEPARTMENT OF PUBLIC WORKS

February 13, 2024

### CERTIFICATE AND NOTICE OF CLOSURE

STATE OF NEW YORK:

COUNTY OF ERIE: }SS

This is to certify that the Commissioner – Highways has jurisdiction of the highways of the County of Erie and does hereby restrict traffic patterns for that portion of the highway in the Town of Boston, said County, known as Erie, and described as follows:

#### Restriction:

The portion of Boston State Road (CR 227) between Boston Cross Rd and Leibler Rd will have a single lane road restriction. Work will be daily between the hours of 7am to 4:30pm, beginning February 19 with an anticipated completion date of February 20<sup>th</sup>, or until complete. This work is for the purpose of make ready work on electrical poles. Erie Net CDC will be performing the work.

A restriction is executed under Article V, Section 104A of the Highway Law in order to permit a proper completion of work of improvement thereon.

IN WITNESS WHEREOF: The undersigned has, on this 13<sup>th</sup> day of February, 2024, set his hand in Buffalo, New York.

Very truly yours,

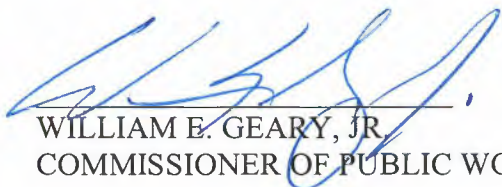
  
WILLIAM E. GEARY, JR.  
COMMISSIONER OF PUBLIC WORKS

WEG/NAK

cc: See Attached List

February 13, 2024  
Boston State Road Restriction  
Page 2

cc: William E Geary Jr., Commissioner of Public Works  
Karen Hoak, Deputy Commissioner of Highways  
Catherine C. Walsh, Special Assistant to the Commissioner  
Garrett Hacker, P.E.  
Darlene Svilokos, P.E.  
Jonathan DePlanche, P.E.  
Gina Wilkolaski, P.E.  
Karl Rohde, P.E.  
Rick Nendza  
Kaitlin Costello  
Kara Nicotra  
Lisa Chimera, Deputy County Executive  
Benjamin Swanekamp, Chief of Staff – Erie County Executive’s Office  
Jordan Zyglis, Legislative Liaison  
Jonathan McNulty, Legislature Senior Admin Clerk  
Daniel Meyer, Deputy Press Secretary for Erie County  
Daniel Neaverth, Dept. of Emergency Services  
Gregory Butcher, Dept. of Emergency Services  
Hon. John J Mills, Legislator, District 11  
Jason A Keding, Supervisor Town of Boston–supervisor@townofboston.com  
Robert Telaak, Town of Boston Highway superintendent–hwysuper@townofboston.com  
Michael Cornell, Hamburg Central School District Superintendent-  
mccornell@hcsdk12.org  
Fisher Bus Service, Hamburg Central School Transportation- service@fisherbus.com  
Anthony Scolese, Hamburg Maintenance District Engineer- Hamburg@erie.gov  
Operators@NITTEC.org

**(Sent via e-mail)**

# Boston Free Library

9475 Boston State Road \* Boston, New York \* 14025



FEB 9 2024 PM 1:18

February 5, 2024

Supervisor Jason Keding  
8500 Boston State Road  
Boston, NY 14025

Dear Supervisor Keding,

On behalf of everyone at the Boston Free Library, thank you and the Boston Town Board for securing \$1,000 for the Library by renewing the Lease and Depository Agreement for 2024. Your support reaffirms the mission of the library which is dedicated to providing books, technology, programs, and entertainment to all of our patrons.

The Library Board of Trustees, staff and patrons are so grateful that you recognize that libraries are a crucial part of our communities. We look forward to using the aid you have provided for us to expand the programs and services that we offer to benefit all of the residents of our service area and to complete building repairs and improvements.

We greatly appreciate your support and advocacy on our behalf.

Sincerely,

A handwritten signature in blue ink that reads "Lydia Herren".

Lydia Herren  
Library Director  
Boston Free Library





## ERIE COUNTY WATER AUTHORITY

3030 Union Road • Cheektowaga, New York 14227-1097  
716-684-1510 • FAX 716-684-3937

To: The Honorable Jason A. Keding, Supervisor  
Town of Boston  
8500 Boston State Road  
Boston, NY 14025

Date: January 25, 2024

Subject: Lead and Copper Rule Revisions (LCRR) and Lead and Copper Rule Improvements (LCRI) –  
Reminder of Requirements and Responsibilities

Dear Supervisor Keding:

We are writing to remind you about the revisions to the Lead and Copper Rule, known as the Lead and Copper Rule Revisions (LCRR), enacted by the United States Environmental Protection Agency (USEPA) in 2021 and the recently announced draft Lead and Copper Rule Improvements (LCRI) which were published in the Federal Register in December 2023. The draft LCRI contains provisions that may lower the lead action level and require the removal of all lead service lines. USEPA intends to finalize the LCRI prior to October 16, 2024. ECWA will provide additional information on the requirements and responsibilities of our lease managed customers when the LCRI is finalized.

The current requirements of the LCRR aim to increase transparency and reduce exposure to lead and copper in drinking water. It is crucial that we comply with these new regulations to continue providing safe drinking water for our customers.

### **Erie County Water Authority Is Taking Action Now**

The Authority is committed to providing safe drinking water to its customers, and therefore we have developed a dedicated program to address the LCRR and LCRI requirements and are acting now to implement that program. Key actions we are taking include:

- Updating our inventory of service line materials including those in our lease managed areas, and working with direct service and lease managed customers to inspect service lines across the system. Our service line inventory will be publicly available online to our customers by the October 16, 2024, LCRR deadline.
- Developing a proactive lead service line replacement program and plan for submittal to the primacy agency by the October 16, 2024, LCRR deadline.
- Implementing new tools to improve communications with our customer and information tracking to ensure regulatory compliance.
- Conducting a study on harvested lead service lines to identify recommended improvements to our current corrosion control treatment strategy to reduce potential lead and copper exposure to our customers. The study is expected to conclude in early 2025 and aims to provide recommendations that will further optimize and enhance our current water treatment process.

To: The Honorable Jason A. Keding, Supervisor  
Town of Boston

January 25, 2024

**As A Lease Managed Customer, What Are My Responsibilities?**

As a lease managed customer, you have certain responsibilities under the LCRR, as outlined below, and are responsible for all capital improvements including replacement of lead service lines if required. Erie County Water Authority can provide technical resources to you to help meet these requirements.

As a lease managed customer, the LCRR requirements stipulate that your system must:

- Coordinate with ECWA for a plan to replace lead service lines (if required) unless all service lines within your system can be shown to be non-lead. ECWA will prepare and submit the Lead Service Line Replacement Plan to the primacy agency.
- Conduct full lead service line replacements and assist the Authority to perform education and outreach, if the 90th percentile for all lead samples in a monitoring round is above the new lead trigger level of 10 ppb. The pending LCRI may require these replacements be completed regardless of 90th percentile results.

More detail on the requirements of the LCRR and draft LCRI can be found in the attached Fact Sheet prepared by US EPA.

Erie County Water Authority is here to help and collaborate with you to improve public health in our communities. We are happy to meet or discuss LCRR and LCRI requirements in further detail.

For any additional questions, please contact Leonard F. Kowalski, PE at 716-685-8220 or at lkowalski@ecwa.org.

Sincerely yours,

ERIE COUNTY WATER AUTHORITY



Leonard F. Kowalski, PE  
Executive Engineer



Charles E. Eaton  
Chief Operating Officer

LFK:CEE:MWW:jmf  
Attachment  
cc: M.Wymer, PE  
S.Figler





## Proposed Lead and Copper Rule Improvements Rule Comparison Guide for Public Water Systems and Primacy Agencies November 2023

The United States Environmental Protection Agency (EPA) is proposing the Lead and Copper Rule Improvements (LCRI) to protect children and adults from the significant, and irreversible, health effects from being exposed to lead in drinking water. The proposal builds on the 2021 Lead and Copper Rule Revisions (LCRR) and the 1991 Lead and Copper Rule (LCR). EPA has developed this rule comparison guide to assist water systems and primacy agencies (also referred to as “States” in this document) in understanding the proposed LCRI. The following table compares the major differences among the LCR, the LCRR, and proposed LCRI.

*Note a similar table can be found in the preamble for the proposed LCRI, available at [www.regulations.gov](http://www.regulations.gov), Docket ID No. EPA-HQ-OW-2022-0801. This table provides additional detail on clarification of requirements retained from previous lead and copper regulations to assist the reader in further understanding the lead and copper rules along with proposed requirements in the LCRI.*

Pre-2021 LCR	LCRR	Proposed LCRI
<b>Service Line Inventory</b>		
<ul style="list-style-type: none"> <li>Systems were required to complete a materials evaluation by the time of initial sampling.</li> <li>No requirement to update materials evaluation.</li> </ul>	<ul style="list-style-type: none"> <li>All systems must develop an initial lead service line (LSL) inventory within 3 years of final rule publication (by October 16, 2024).</li> <li>The inventory must include a location identifier for each LSL and galvanized requiring replacement (GRR) service line.</li> <li>The inventory must be made publicly accessible; and available online for systems serving &gt; 50,000 people.</li> <li>The LSL inventory must be updated at a frequency based on the system’s tap sampling frequency but no more than annually.</li> </ul>	<ul style="list-style-type: none"> <li>All systems must review records for information on connector materials and include lead connectors in the LCRI baseline inventory by the compliance date.</li> <li>The inventory must include a street address with each service line and connector.</li> <li>Retains the LCRR requirement for the inventory to be made publicly accessible; and available online for systems serving &gt; 50,000 people.</li> <li>Service line inventory must be updated annually.</li> </ul>

Pre-2021 LCR	LCRR	Proposed LCRI
		<ul style="list-style-type: none"> <li>• Systems must respond to customer inquiries on incorrect material categorizations within 60 days.</li> <li>• Systems must validate the accuracy of the non-lead service line category in their inventory no later than 7 years after the compliance date unless on a shortened or deferred deadline.</li> <li>• Systems must identify all unknown service lines by the applicable mandatory replacement deadline.</li> </ul>
<b><i>Service Line Replacement</i></b>		
<p><b>Replacement Plan</b></p> <ul style="list-style-type: none"> <li>• No requirement.</li> </ul>	<p><b>Replacement Plan</b></p> <ul style="list-style-type: none"> <li>• Systems with at least one lead, GRR, or unknown service line must develop a lead service line replacement (LSLR) plan.</li> <li>• The plan must include strategies for identifying unknowns; procedures for full service line replacement; a customer communication strategy; flushing instructions; a strategy to prioritize replacements based on factors including but not limited to the targeting of known LSLs, LSLR for disadvantaged consumers and populations most sensitive to the effects of lead; and a funding strategy.</li> <li>• No requirement to make the plan publicly accessible.</li> </ul>	<p><b>Replacement Plan</b></p> <ul style="list-style-type: none"> <li>• All systems with at least one lead, GRR, or unknown service line must develop the service line replacement plan (with all elements required in the LCRR).</li> <li>• The plan must also include additional elements including a strategy to inform customers and consumers about the plan and replacement program and an identification of any legal requirements or water tariff agreement provisions that affect a system’s ability to gain access to conduct full service line replacement.</li> <li>• Updates the language on the replacement prioritization strategy.</li> <li>• Service line replacement plan must be made publicly accessible; and available online for systems serving &gt; 50,000 people.</li> </ul>
<p><b>LSLR</b></p> <ul style="list-style-type: none"> <li>• Replacement programs are based on the lead 90<sup>th</sup> percentile (P90) level, corrosion control treatment (CCT) installation, and/or source water treatment.</li> </ul>	<p><b>LSLR</b></p> <ul style="list-style-type: none"> <li>• Replacement programs are based on P90 lead level for community water systems (CWSs) serving &gt; 10,000 people:</li> </ul>	<p><b>Service Line Replacement</b></p> <ul style="list-style-type: none"> <li>• Mandatory full service line replacement program for all systems.</li> <li>• All CWSs and NTNCWSs with one or more lead, GRR, or unknown service line in their</li> </ul>

Pre-2021 LCR	LCRR	Proposed LCRI
<ul style="list-style-type: none"> <li>• Systems with LSLs with P90 lead &gt; 0.015 mg/L after CCT installation must annually replace at least 7 percent of number of LSLs in their distribution system when the lead action level is first exceeded.</li> <li>• Systems must replace the LSL portion they own and offer to replace the private portion at the owner’s expense.</li> <li>• Full LSLR, partial LSLR, and LSLs with lead sample results ≤ 0.015 mg/L (“test-outs”) count toward the 7 percent replacement rate.</li> <li>• Systems can discontinue LSLR after 2 consecutive 6-month monitoring periods at or below the lead action level.</li> <li>• Requires replacement of LSLs only.</li> </ul>	<ul style="list-style-type: none"> <li>○ If P90 &gt; 0.015 mg/L: Must fully replace 3 percent of LSLs and GRR service lines per year based upon a 2-year rolling average (mandatory replacement) for at least 4 consecutive 6-month monitoring periods.</li> <li>○ If 0.010 mg/L &lt; P90 ≤ 0.015 mg/L: Implement a goal-based LSLR program and consult the primacy agency (or State) on replacement goals for 2 consecutive 1-year monitoring periods.</li> <li>• CWSs serving ≤ 10,000 people and all non-transient, non-community water systems (NTNCWSs) that select LSLR as their compliance option must complete LSLR within 15 years if P90 &gt; 0.015 mg/L. Also, see the <i>Small System Flexibility</i> section of this fact sheet.</li> <li>• Annual LSLR rate is applied to the number of LSLs and GRR service lines when the system first exceeds the trigger or action level plus the number of unknown service lines at the beginning of the year.</li> <li>• Only full LSLR (replacement of the entire length of the service line) counts toward mandatory rate and goal-based rate. No “test-outs.”</li> <li>• All systems replace their portion of an LSL if notified by consumer of private side replacement within 45 days of notification of the private replacement. If the system cannot replace the system’s portion within 45 days, it must notify the State and replace the system’s portion within 180 days.</li> <li>• Following each LSLR, systems must:</li> </ul>	<p>inventory must replace LSLs and GRR service lines under their control in 10 years. Systems required to replace &gt;10,000 lines per year or systems exceeding 0.039 replacements per household per year would be eligible for deferred deadlines beyond the 10-year replacement deadline. Systems must replace service lines by a shortened deadline if determined feasible by the State.</p> <ul style="list-style-type: none"> <li>• Systems must replace service lines at a minimum average annual rate of 10 percent calculated on a rolling 3-year period unless subject to a shortened or deferred deadline.</li> <li>• Average annual replacement rate is applied to the number of LSLs and GRR service lines in the baseline inventory submitted by the compliance date plus the number of unknown service lines updated annually.</li> <li>• Systems must conduct reasonable efforts (at least 4 attempts) to engage property owners about full service line replacement, when applicable.</li> <li>• LCRR requirements remain for counting only full service line replacements towards replacement rate, completing customer-initiated replacements, providing a filter and offering tap sampling following replacements, and replacing lead connectors when encountered.</li> <li>• Systems conducting partial service line replacement must offer to replace the remaining portion of the service line not under their control (within 45 days for emergencies).</li> </ul>

Pre-2021 LCR	LCRR	Proposed LCRI
	<ul style="list-style-type: none"> <li>○ Provide pitcher filters and cartridges to each customer for 6 months after replacement. Provide pitcher filters and cartridges before the affected portion of the line or the fully replaced service line is returned to service.</li> <li>○ Collect a lead tap sample at locations served by the replaced line within 3 to 6 months after replacement.</li> <li>● Requires replacement of lead connectors when encountered.</li> <li>● Systems must make 2 good faith efforts to engage customers about LSLR.</li> <li>● Systems conducting partial LSLR must offer to replace the portion of the service line.</li> </ul>	
<p><b>LSL-Related Outreach</b></p> <ul style="list-style-type: none"> <li>● When a water system plans to replace the portion it owns, it must offer to replace the customer-owned portion at owner's expense.</li> <li>● If a system replaces its portion only: <ul style="list-style-type: none"> <li>○ Provide notification to affected residences within 45 days prior to replacement on possible elevated short-term lead levels and measures to minimize exposure.</li> <li>○ Include offer to collect lead tap sample within 72 hours of replacement.</li> <li>○ Provide test results within 3 business days after receiving results.</li> </ul> </li> </ul>	<p><b>LSL-Related Outreach</b></p> <ul style="list-style-type: none"> <li>● Notify consumers annually if they are served by a lead, GRR, or unknown service line.</li> <li>● Deliver notice and educational materials to consumers during water-related work that could disturb LSLs.</li> <li>● Systems subject to goal-based program must: <ul style="list-style-type: none"> <li>○ Conduct targeted outreach that encourages consumers with LSLs to participate in the LSLR program.</li> <li>○ Conduct an additional outreach activity if they fail to meet their goal.</li> </ul> </li> </ul> <p>Systems subject to mandatory LSLR must include information about the LSLR program in public education (PE) materials that are provided in response to P90 &gt; action level.</p>	<p><b>Service Line Related Outreach</b></p> <ul style="list-style-type: none"> <li>● Maintains LCRR requirement to notify consumers annually if they are served by a lead, GRR, or unknown service line.</li> <li>● Deliver notice and educational materials to consumers during water-related work that could disturb lead, GRR, or unknown service lines, including disturbances due to inventorying efforts.</li> <li>● If the system fails to meet the mandatory service line replacement rate, conduct public outreach activities to encourage consumers with lead, GRR, and unknown service lines to participate in the service line replacement program.</li> <li>● Removes goal-based program outreach activities.</li> </ul>



Pre-2021 LCR	LCRR	Proposed LCRI
<b>Action Level and Trigger Level</b>		
<ul style="list-style-type: none"> <li>• P90 level above lead action level of 0.015 mg/L or copper action level of 1.3 mg/L requires additional actions.</li> <li>• Lead action level exceedance requires 7 percent LSLR (includes partial replacements), CCT recommendation and possible study and installation, and PE within 60 days after the end of the monitoring period.</li> </ul>	<ul style="list-style-type: none"> <li>• P90 level above lead action level of 0.015 mg/L or copper action level of 1.3 mg/L requires more actions than the previous rule.</li> <li>• Defines lead trigger level of 0.010 mg/L &lt; P90 ≤ 0.015 mg/L that triggers additional planning, monitoring, and treatment requirements.</li> <li>• Trigger level exceedance requires goal-based LSLR and steps taken towards CCT installation or re-optimization.</li> <li>• Lead action level exceedance requires 3 percent LSLR (no partial replacements), CCT installation or re-optimization, PE, and public notification (PN) within 24 hours.</li> </ul>	<ul style="list-style-type: none"> <li>• Removes the lead trigger level.</li> <li>• P90 level above lead action level of 0.010 mg/L or copper action level of 1.3 mg/L requires actions including installation or re-optimization of CCT, and PE and 24-hour PN (for lead action level exceedances).</li> <li>• Mandatory full service line replacement of LSLs and GRR service lines is independent of P90 lead levels.</li> </ul>
<b>Lead and Copper Tap Monitoring</b>		
<p><b>Sample Site Selection</b></p> <ul style="list-style-type: none"> <li>• Prioritizes collection of samples from sites with sources of lead in contact with drinking water.</li> <li>• Highest priority given to sites served by copper pipes with lead solder installed after 1982 or containing lead pipes and sites served by LSLs.</li> <li>• Systems must collect 50 percent of samples from LSLs, if available.</li> </ul>	<p><b>Sample Site Selection</b></p> <ul style="list-style-type: none"> <li>• Changes priorities for collection of samples with a greater focus on LSLs.</li> <li>• Prioritizes collecting samples from sites served by LSLs. All samples must be collected from sites served by LSLs, if available.</li> <li>• No distinction in prioritization of copper pipes with lead solder by installation date.</li> <li>• Adds 2 tiers to focus tap sample site selection tiering criteria on LSLs first.</li> </ul>	<p><b>Sample Site Selection</b></p> <ul style="list-style-type: none"> <li>• Retains LCRR requirement that all samples be collected from sites served by LSLs, if available.</li> <li>• Combines the tap sample site selection tiering criteria for CWSs and NTNCWSs.</li> <li>• Revises Tier 3 sites to include sites served by a lead connector as well as sites served by a galvanized service line or containing galvanized premise plumbing that are identified as ever being downstream of an LSL or lead connector in the past.</li> </ul>
<p><b>Collection and Analysis</b></p> <ul style="list-style-type: none"> <li>• Requires collection of the first-liter sample after water has sat stagnant for a minimum of 6 hours.</li> </ul>	<p><b>Collection and Analysis</b></p> <ul style="list-style-type: none"> <li>• Requires collection of the fifth-liter sample in homes with LSLs after water has sat stagnant for a minimum of 6 hours. Maintains first-liter sampling protocol in homes without LSLs.</li> </ul>	<p><b>Collection and Analysis</b></p> <ul style="list-style-type: none"> <li>• Requires collection of first- and fifth-liter samples in homes with LSLs after water has sat stagnant for a minimum of 6 hours.</li> <li>• Requires the higher value of the first- and fifth-liter lead concentration in homes with</li> </ul>

Pre-2021 LCR	LCRR	Proposed LCRI
	<ul style="list-style-type: none"> <li>• Adds requirement that samples must be collected in wide-mouth bottles.</li> <li>• Prohibits sampling instructions that include recommendations for aerator cleaning/ removal and pre-stagnation flushing prior to sample collection.</li> </ul>	<ul style="list-style-type: none"> <li>• LSLs to be used to calculate the 90<sup>th</sup> percentile value for lead.</li> <li>• Clarifies the definition of a wide-mouth bottle.</li> <li>• Retains the LCRR sampling instruction prohibitions.</li> </ul>
<p><b>Monitoring Frequency</b></p> <ul style="list-style-type: none"> <li>• Samples are analyzed for both lead and copper.</li> <li>• Systems must collect standard number of samples based on population; semi-annually unless they qualify for reduced monitoring.</li> <li>• Systems can qualify for annual or triennial monitoring at reduced number of sites. Monitoring schedule based on the number of consecutive years meeting the following criteria: <ul style="list-style-type: none"> <li>○ Serves ≤ 50,000 people and P90 is at or below the lead and copper action levels, respectively.</li> <li>○ Serves any population size, meets State-specified optimized water quality parameters (OWQPs), and P90 ≤ lead action level.</li> </ul> </li> <li>• Triennial monitoring also applies to any system with lead P90 ≤ 0.005 mg/L and copper P90 ≤ 0.65 mg/L for 2 consecutive 6-month monitoring periods.</li> <li>• Based on rule criteria, systems serving ≤ 3,300 people can apply for a 9-year monitoring waiver.</li> </ul>	<p><b>Monitoring Frequency</b></p> <ul style="list-style-type: none"> <li>• Samples are analyzed for lead and copper, only copper, or only lead. This occurs when lead monitoring is conducted more frequently or at more sites than copper, and at LSL sites where a fifth-liter sample is only analyzed for lead.</li> <li>• Lead monitoring schedule is based on the P90 level for all systems as follows: <ul style="list-style-type: none"> <li>○ P90 &gt; 0.015 mg/L: Semi-annually at the standard number of sites.</li> <li>○ 0.010 mg/L &lt; P90 ≤ 0.015 mg/L: Annually at the standard number of sites.</li> <li>○ P90 ≤ 0.010 mg/L: Annually at the standard number of sites and triennially at reduced number of sites using same criteria as the LCR except copper P90 level is not considered.</li> </ul> </li> <li>• Based on rule criteria, systems serving ≤ 3,300 people can apply for a 9-year monitoring waiver.</li> </ul>	<p><b>Monitoring Frequency</b></p> <p>Monitoring schedule is based on both lead and copper P90 levels for all systems as follows:</p> <ul style="list-style-type: none"> <li>• All water systems with lead, GRR, and/or unknown service lines must begin by collecting a standard number of samples semi-annually.</li> <li>• Systems may retain or qualify for reduced monitoring based on the number of consecutive monitoring periods: <ul style="list-style-type: none"> <li>○ P90 ≤ action level for 2 consecutive 6-month periods: Annual monitoring at the standard number of sites for lead and reduced number of sites for copper.</li> <li>○ P90 ≤ practical quantitation limit (PQL) for 2 consecutive 6-month periods: Triennial monitoring at the reduced number of sites.</li> </ul> </li> <li>• Additional criteria for small and medium systems to qualify for triennial monitoring.</li> <li>• Based on rule criteria, systems serving ≤ 3,300 people can apply for a 9-year monitoring waiver.</li> </ul>

Pre-2021 LCR	LCRR	Proposed LCRI
<b>Corrosion Control Treatment (CCT) and Water Quality Parameters (WQPs)</b>		
<p><b>CCT</b></p> <ul style="list-style-type: none"> <li>Systems serving &gt; 50,000 people were required to install treatment by January 1, 1997, with limited exception.</li> <li>Systems serving ≤ 50,000 that exceed the lead and/or copper action level(s) are subject to CCT requirements (e.g., CCT recommendation, study if required by the State, CCT installation). They can discontinue CCT steps if no longer exceed both action levels for 2 consecutive 6-month monitoring periods.</li> <li>Systems must operate CCT to meet any OWQPs designated by the State that define optimal CCT (OCCT).</li> <li>There is no requirement for systems to re-optimize.</li> </ul>	<p><b>CCT</b></p> <ul style="list-style-type: none"> <li>Specifies CCT requirements for systems with <math>0.010 &lt; \text{P90 lead level} \leq 0.015 \text{ mg/L}</math>: <ul style="list-style-type: none"> <li>No CCT: Must conduct a CCT study if required by the State.</li> <li>With CCT: Must follow the steps for re-optimizing CCT, as specified in the rule.</li> </ul> </li> <li>Systems with P90 lead level &gt; 0.015 mg/L: <ul style="list-style-type: none"> <li>No CCT: Must complete CCT installation regardless of their subsequent P90 levels if system has started to install CCT.</li> <li>With CCT: Must re-optimize CCT.</li> </ul> </li> <li>CWSs serving ≤ 10,000 people and all NTNCWSs can select an option other than CCT to address lead. Also, see the <i>Small System Flexibility</i> section of this fact sheet.</li> </ul>	<p><b>CCT</b></p> <ul style="list-style-type: none"> <li>Systems with P90 lead level &gt; 0.010 mg/L: <ul style="list-style-type: none"> <li>No CCT: Must complete CCT installation regardless of their subsequent P90 levels if system has started to install CCT.</li> <li>With CCT: Must re-optimize CCT.</li> <li>Systems with OCCT meeting OWQPs need only re-optimize OCCT once, unless required to do so by the State.</li> </ul> </li> <li>CWSs serving ≤ 3,300 people and all NTNCWSs can select an option other than CCT to address lead. Also, see the <i>Small System Flexibility</i> section of this fact sheet.</li> <li>Deferred OCCT or re-optimized OCCT for systems that can complete removal of 100 percent LSLs and GRR service lines within 5 years of the date they are triggered into CCT steps at a 20 percent annual replacement rate. Systems with CCT must maintain CCT during the 5-year service line replacement program.</li> </ul>
<p><b>CCT Options</b></p> <p>Includes alkalinity and pH adjustment, calcium hardness adjustment, and phosphate or silicate-based corrosion inhibitor.</p>	<p><b>CCT Options</b></p> <p>Removes calcium hardness as an option and specifies any phosphate inhibitor must be orthophosphate.</p>	<p><b>CCT Options</b></p> <p>No changes from the LCRR.</p>
<p><b>WQPs</b></p> <ul style="list-style-type: none"> <li>No CCT: pH, alkalinity, calcium, conductivity, temperature, orthophosphate (if phosphate-based inhibitor is used), silica (if silica-based inhibitor is used).</li> <li>With CCT: pH, alkalinity, and based on type of CCT either orthophosphate, silica, or calcium.</li> </ul>	<p><b>WQPs</b></p> <ul style="list-style-type: none"> <li>Eliminates WQPs related to calcium hardness (i.e., calcium, conductivity, and temperature).</li> <li>All other parameters are the same as the LCR.</li> </ul>	<p><b>WQPs</b></p> <ul style="list-style-type: none"> <li>No changes from the LCRR.</li> </ul>

Pre-2021 LCR	LCRR	Proposed LCRI
<p><b>WQP Monitoring</b></p> <ul style="list-style-type: none"> <li>• Systems serving &gt; 50,000 people must conduct regular WQP monitoring at entry points and within the distribution system.</li> <li>• Systems serving ≤ 50,000 people conduct monitoring only in those periods &gt; lead or copper action level.</li> <li>• Contains provisions to sample at reduced number of sites in distribution system less frequently for all systems meeting their OWQPs.</li> </ul>	<p><b>WQP Monitoring</b></p> <ul style="list-style-type: none"> <li>• Systems serving &gt; 50,000 people must conduct regular WQP monitoring at entry points and within the distribution system.</li> <li>• Systems serving ≤ 50,000 people must continue WQP monitoring until they no longer &gt; lead and/or copper action level(s) for 2 consecutive 6-month monitoring periods.</li> <li>• To qualify for reduced WQP distribution monitoring, P90 lead level must be ≤ 0.010 mg/L and the system must meet its OWQPs.</li> </ul>	<p><b>WQP Monitoring</b></p> <ul style="list-style-type: none"> <li>• Systems with CCT (unless deemed optimized) serving ≥ 10,000 people must conduct regular WQP monitoring at entry points and within the distribution system.</li> <li>• Systems serving &lt;10,000 people and systems without CCT serving ≤ 50,000 people that exceed the lead and/or copper action level(s) must continue WQP monitoring until they no longer exceed lead and/or copper action level(s) for 2 consecutive 6-month monitoring periods.</li> <li>• Systems without CCT serving &gt; 10,000 but ≤ 50,000 people that exceed the lead action level that are required to install CCT, must continue to conduct WQP monitoring.</li> </ul>
<p><b>Sanitary Survey Review</b> Treatment must be reviewed during sanitary surveys; no specific requirement to assess CCT or WQPs.</p>	<p><b>Sanitary Survey Review</b> CCT and WQP data must be reviewed during sanitary surveys against most recent CCT guidance issued by EPA.</p>	<p><b>Sanitary Survey Review</b> No changes from the LCRR.</p>
<p><b>Find-and-Fix</b> No required follow-up samples or additional actions if an individual sample exceeds the lead action level.</p>	<p><b>Find-and-Fix</b> If individual tap samples &gt; 0.015 mg/L lead, find-and-fix steps include:</p> <ul style="list-style-type: none"> <li>• Conduct WQP monitoring at or near the site &gt; 0.015 mg/L.</li> <li>• Collect tap sample at the same tap sample site within 30 days. <ul style="list-style-type: none"> <li>○ For LSL, collect any liter or sample volume.</li> <li>○ If LSL is not present, collect 1-liter first draw after stagnation.</li> </ul> </li> <li>• Perform needed corrective action.</li> <li>• Document customer refusal or nonresponse after 2 attempts.</li> <li>• Provide information to local and State public health officials.</li> </ul>	<p><b>Distribution System and Site Assessment</b></p> <ul style="list-style-type: none"> <li>• Changes the name from “Find-and-Fix” to “Distribution System and Site Assessment” to describe this requirement more precisely.</li> <li>• Requirements from the LCRR affect systems with individual tap samples &gt; 0.010 mg/L lead.</li> <li>• Clarifies that the distribution system sample location must be within a half mile radius of each site with a result &gt; 0.010 mg/L.</li> </ul>



Pre-2021 LCR	LCRR	Proposed LCRI
<b><i>Small System Flexibility</i></b>		
<p>No provisions for systems to elect an alternative treatment approach but sets specific requirements for CCT and LSLR.</p>	<p>Allows CWSs serving <math>\leq 10,000</math> people and all NTNCWSs with lead P90 <math>&gt; 0.010</math> mg/L to select their compliance option to address lead with State approval:</p> <ul style="list-style-type: none"> <li>• Systems can choose CCT, LSLR, provision and maintenance of point-of-use (POU) devices, or replacement of all lead-bearing plumbing materials.</li> <li>• If the system's P90 lead level <math>&gt; 0.015</math> mg/L, the system must implement the compliance option.</li> </ul>	<p>Allows CWSs serving <math>\leq 3,300</math> people and all NTNCWSs with P90 levels <math>&gt;</math> lead action level and <math>\leq</math> copper action level to conduct the following actions in lieu of CCT requirements to address lead with State approval:</p> <ul style="list-style-type: none"> <li>• Choose a compliance option: (1) provision and maintenance of POU devices or (2) replacement of all lead-bearing plumbing materials.</li> <li>• Removes the compliance option to conduct LSLR in 15 years.</li> </ul> <p>Maintains option for systems following CCT requirements:</p> <ul style="list-style-type: none"> <li>• With CCT: Collect WQPs and evaluate compliance options and OCCT.</li> <li>• No CCT: Evaluate compliance options and CCT.</li> </ul>
<b><i>Public Education and Outreach</i></b>		
<ul style="list-style-type: none"> <li>• Systems with P90 <math>&gt;</math> lead action level must provide PE to customers about lead sources, health effects, measures to reduce lead exposure, and additional information sources.</li> <li>• Systems with P90 <math>&gt;</math> lead action level must offer lead tap sampling to customers who request it.</li> <li>• Systems must provide lead consumer notice to individuals served at tested taps within 30 days of learning results.</li> <li>• For water systems serving a large proportion of consumers with limited English proficiency, consumers can contact the system to get PE materials translated in other languages.</li> </ul>	<ul style="list-style-type: none"> <li>• Water systems must provide updated lead health effects language in PN and PE materials. CWSs must provide updated health effects language in the Consumer Confidence Report (CCR).</li> <li>• For water systems serving a large proportion of consumers with limited English proficiency, consumers can contact the system to get PE materials translated in other languages.</li> <li>• If P90 <math>&gt;</math> lead action level: <ul style="list-style-type: none"> <li>○ LCR PE requirements apply.</li> </ul> </li> <li>• Water systems must provide the lead consumer notice to consumers whose individual tap sample is <math>&gt; 0.015</math> mg/L lead as soon as practicable but no later than 3 days.</li> <li>• Water systems must deliver notice and</li> </ul>	<ul style="list-style-type: none"> <li>• Revises the mandatory lead health effects language to improve completeness and clarity.</li> <li>• Water systems must provide the updated health effects language in PN and all PE materials. CWSs must provide updated health effects language in the CCR.</li> <li>• For water systems serving a large proportion of consumers with limited English proficiency, all PE materials must include a translated statement regarding the importance of the materials and consumers can contact the system to get the materials translated in other languages.</li> <li>• Water systems must deliver consumer notice of lead and copper tap sampling results to</li> </ul>

Pre-2021 LCR	LCRR	Proposed LCRI
	<p>educational materials to consumers during water-related work that could disturb LSLs.</p> <ul style="list-style-type: none"> <li>• CWSs must provide information to local and State health agencies.</li> </ul> <p>Also, see the <i>Public Notification, Consumer Confidence Report, and LSL-Related Outreach</i> sections of this fact sheet.</p>	<p>consumers whose tap was sampled as soon as practicable but no later than 3 days after receiving the results.</p> <ul style="list-style-type: none"> <li>• If P90 &gt; lead action level: <ul style="list-style-type: none"> <li>○ LCRR PN requirements apply.</li> <li>○ Water systems must conduct PE no later than 60 days after the end of the tap sampling period until the system no longer exceeds the action level unless the State approves an extension.</li> </ul> </li> <li>• Water systems with multiple lead action level exceedances (at least 3 action level exceedances in a 5-year period) must conduct additional public outreach activities and make filters available.</li> <li>• Water systems must offer to sample the tap for lead for any customer with a lead, GRR, or unknown service line who requests it.</li> <li>• Water systems must deliver notice and educational materials to consumers during water-related work that could disturb LSLs.</li> <li>• CWSs must provide information to local and State health agencies.</li> </ul> <p>Also, see the <i>Public Notification, Consumer Confidence Report, and Service Line Related Outreach</i> sections of this fact sheet.</p>
<b>Public Notification</b>		
<ul style="list-style-type: none"> <li>• If P90 &gt; action level: <ul style="list-style-type: none"> <li>○ No PN required for P90 &gt; action level.</li> </ul> </li> <li>• Tier 2 PN required for treatment technique violations to § 141.80 through § 141.85.</li> <li>• Tier 3 PN required for monitoring and reporting violations to § 141.86 through § 141.89.</li> </ul>	<ul style="list-style-type: none"> <li>• If P90 &gt; lead action level: <ul style="list-style-type: none"> <li>○ Systems must notify consumers of P90 &gt; action level within 24 hours (Tier 1 PN).</li> </ul> </li> <li>• Tier 2 PN required for violations to § 141.80 (except § 141.80(c)) through § 141.84, § 141.85(a) through (c) and (h), and § 141.93.</li> <li>• Tier 3 PN required for violations to § 141.86 through § 141.90.</li> </ul>	<ul style="list-style-type: none"> <li>• If P90 &gt; lead action level: <ul style="list-style-type: none"> <li>○ LCRR Tier 1 PN requirements apply.</li> </ul> </li> <li>• Tier 2 PN required for violations to § 141.80 (except § 141.80(c)) through § 141.84, § 141.85(a) through (c) (except § 141.85(c)(3)) and (h) and (j), and § 141.93.</li> <li>• Tier 3 PN required for violations to § 141.86 through § 141.90 and § 141.92.</li> </ul>

Pre-2021 LCR	LCRR	Proposed LCRI
Also, see <i>Public Education and Outreach</i> section of this fact sheet.	<ul style="list-style-type: none"> <li>Also, see <i>Public Education and Outreach</i> section of this fact sheet.</li> </ul>	<ul style="list-style-type: none"> <li>Water systems must provide updated lead health effects language in PN.</li> <li>Also, see <i>Public Education and Outreach</i> section of this fact sheet.</li> </ul>
<b>Consumer Confidence Report</b>		
<ul style="list-style-type: none"> <li>All CWSs must provide educational material in the annual CCR.</li> </ul>	<ul style="list-style-type: none"> <li>CWSs must provide updated health effects language in the CCR.</li> <li>All CWSs are required to include information on how to access the LSL inventory and how to access the results of all tap sampling in the CCR.</li> <li>Revises the mandatory health effects language to improve accuracy and clarity.</li> </ul>	<ul style="list-style-type: none"> <li>Revises the mandatory lead health effects language and informational statement about lead in the CCR to improve completeness and clarity.</li> <li>CWSs must provide updated health effects language in the CCR.</li> <li>CWSs must provide an updated informational statement about lead in the CCR.</li> <li>CWSs must include a statement in the CCR about the system sampling for lead in schools and child care facilities and may direct the public to contact their school or child care facility for further information.</li> <li>CWSs with lead, GRR, or unknown service lines must include a statement in the CCR about how to access the service line inventory and replacement plan.</li> <li>Also see <i>Public Education and Outreach</i> section of this fact sheet.</li> </ul>
<b>Change in Source or Treatment</b>		
Systems on a <b>reduced</b> tap monitoring schedule must obtain prior State approval before changing their source or treatment.	Systems on <b>any</b> tap monitoring schedule must obtain prior State approval before changing their source or treatment. These systems must also conduct tap monitoring biannually.	No changes from the LCRR.
<b>Source Water Monitoring and Treatment</b>		
Periodic source water monitoring for lead and copper is required for systems with: <ul style="list-style-type: none"> <li>Source water treatment; or</li> </ul>	States can waive continued source water monitoring for lead and copper if the:	No changes from the LCRR.

Pre-2021 LCR	LCRR	Proposed LCRI
<ul style="list-style-type: none"> <li>• P90 &gt; action level and no source water treatment.</li> </ul>	<ul style="list-style-type: none"> <li>• System has already conducted source water monitoring for a previous P90 &gt; action level;</li> <li>• State has determined that source water treatment is not required; and</li> <li>• System has not added any new water sources.</li> </ul>	
<b>Lead in Drinking Water at Schools and Child Care Facilities</b>		
<ul style="list-style-type: none"> <li>• Does not include separate testing and education program for CWSs at schools and child care facilities.</li> <li>• Schools and child care facilities that are classified as NTNCWSs must sample for lead and copper.</li> </ul>	<ul style="list-style-type: none"> <li>• CWSs must conduct sampling at 20 percent of elementary schools and 20 percent of child care facilities per year and conduct sampling at secondary schools on request for first testing cycle (5 years) and conduct sampling on request of all schools and child care facilities thereafter.</li> <li>• Sample results and PE must be provided to each sampled school/child care facility, State, and local or State health department.</li> <li>• Excludes facilities constructed on or after January 1, 2014.</li> <li>• Waives schools and child care facilities that were sampled under a State or other program after October 16, 2024.</li> </ul>	<p>Expands the waiver to include:</p> <ul style="list-style-type: none"> <li>• Waivers for CWSs to sample in schools and child care facilities during the first 5-year testing cycle if the facility has been sampled between January 1, 2021, and the LCRI compliance date.</li> <li>• Requires CWSs to include a statement about the opportunity for schools and child care facilities to be sampled in the CCR.</li> <li>• Excludes facilities constructed or had full plumbing replacement on or after January 1, 2014.</li> </ul>
<b>Primacy Agency (or State) Reporting</b>		
<p>States must report information to EPA that includes, but is not limited to:</p> <ul style="list-style-type: none"> <li>• All P90 levels for systems serving &gt; 3,300 people, and only levels &gt; 0.015 mg/L for smaller systems.</li> <li>• Systems that are required to initiate LSLR and the date replacement must begin.</li> <li>• Systems for which OCCT has been designated.</li> </ul>	<p>Expands on LCR requirements to include:</p> <ul style="list-style-type: none"> <li>• All P90 values for all system sizes.</li> <li>• The number of lead, GRR, and unknown service lines for every water system.</li> <li>• The goal-based or mandatory replacement rate and the date each system must begin LSLR.</li> <li>• OCCT status of all systems including OWQPs specified by the State.</li> <li>• For systems triggered into source water treatment, the State-designated date or determination for no treatment required.</li> </ul>	<p>Revises and expands on LCRR special primacy requirements. States must report information to EPA that includes, but is not limited to:</p> <ul style="list-style-type: none"> <li>• The current number of lead, GRR, unknown service lines, non-lead service lines, and lead connectors in each system's inventory.</li> <li>• The number and type of service lines replaced and the replacement rate for every system conducting mandatory service line replacement.</li> </ul>



Pre-2021 LCR	LCRR	Proposed LCRI
		<ul style="list-style-type: none"> <li>• The deadline for the system to complete replacement of all lead and GRR service lines.</li> <li>• The expected date of completion of service line replacement.</li> <li>• The P90 values of systems with an action level exceedance within 15 days of the end of the monitoring period or, if earlier, within 24 hours of receiving the notice from the system.</li> </ul>

**Acronyms:** CCR = consumer confidence report; CCT = corrosion control treatment; CWS = community water system; GRR = galvanized requiring replacement; LCR = Lead and Copper Rule; LCRI = Lead and Copper Rule Improvements; LCRR = Lead and Copper Rule Revisions; LSL = lead service line; LSLR = lead service line replacement; NTNCWS = non-transient non-community water system; OCCT = optimal corrosion control treatment; OWQP = optimal water quality parameter; P90 = 90th percentile; PE = public education; PN = public notice; POU = point-of use; WQP = water quality parameter.

For more information on the proposed LCRI, please visit: <https://www.epa.gov/ground-water-and-drinking-water/lead-and-copper-rule-improvements>.

**Disclaimer:** This document is being provided for informational purposes only to assist members of the public, States, Tribes, and/or public water systems in reviewing and commenting on the package for the proposed LCR). In the event that there are any differences, conflicts, or errors between this document and the content included in the package for the proposed LCRI, including the preamble and proposed regulatory text, States, Tribes, and/or public water systems should refer to the rule package. The LCRI is only a proposed rule and the content discussed herein about the proposed LCRI is subject to change before a final LCRI is promulgated. This document does not impose any new legally binding requirements on EPA, States, Tribes, or the regulated community. Further, this document does not confer legal rights or impose legal obligations on any member of the public. In the event of a conflict between the discussion in this fact sheet and any statute or promulgated regulation, the statute and any promulgated regulations are controlling.



# COUNTY OF ERIE

**MARK C. POLONCARZ**

COUNTY EXECUTIVE

Honorable Jason A. Keding

8500 Boston State Road

Boston, NY 14025

As we start the New Year we wanted to share information about the Solid Waste Management Plan that is in place, which includes your municipality.

There are two local solid waste boards in Erie County composed of members from each municipality, the Northwest and the Northeast Southtowns (NEST) Boards. The Boards have regulatory requirements to share information and provide solid waste data and planning documents with the New York State Department of Environmental Conservation. Erie County manages regulatory reporting requirements for the Local Solid Waste Boards by regularly collecting data, creating comprehensive 10-year plans on behalf of the Boards, completing annual and biennial reporting, and providing education and outreach to residents. Erie County also shares new information and initiatives with our Local Solid Waste Boards during their quarterly meetings. The City of Buffalo is not part of either Board as they manage their regulatory requirements separately.

Enclosed for your reference is a copy of the executive summary for your communities' local solid waste board's Local Solid Waste Management Plan. It summarizes the Board-led priorities that will be worked on during this decade. If you have any questions or comments about the plan, please contact Amy Alduino, Erie County Recycling Coordinator, at 716-858-4715 or [amy.alduino@erie.gov](mailto:amy.alduino@erie.gov).

The enclosed calendar features student art related to recycling, waste reduction and climate change. The New York State Association for Reduce, Reuse Recycle (NYSAR3) held a statewide contest asking students to create an illustration about the importance of recycling.

We look forward to working with you and your staff to serve the residents of Erie County. Thank you for your service.



# LOCAL SOLID WASTE MANAGEMENT PLAN

Strategies To Move Beyond Waste 2020-2030

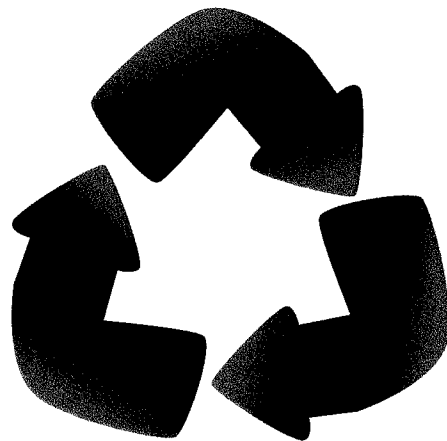

**Prepared by:**  
COUNTY OF ERIE  
DEPARTMENT OF  
ENVIRONMENT & PLANNING

---

# THE NORTHEAST SOUTHTOWNS (NEST) SOLID WASTE MANAGEMENT BOARD

Protecting the health of our citizens and environment by effectively managing solid waste

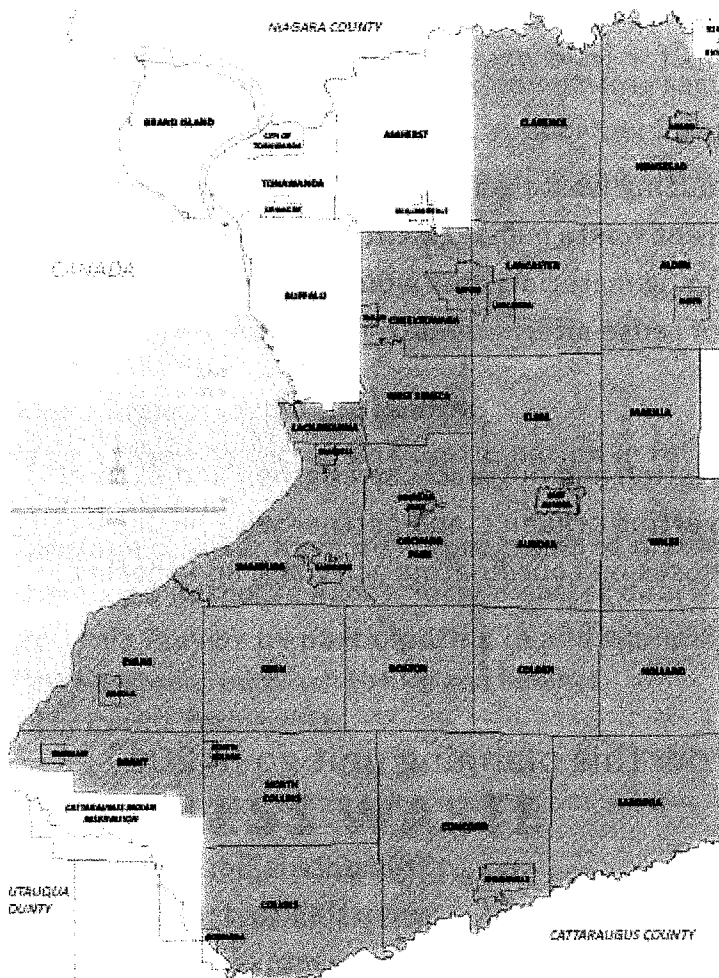

The Northeast Southtowns Solid Waste Management Board (NEST) is a planning unit in Erie County, NY, New York State Department of Environmental Conservation (NYSDEC) Region 9, which encompasses 22 towns, 14 villages and one city.

The NEST planning unit is bounded on the exterior borders of Erie County by the following planning units: Niagara County, GLOW Region Solid Waste Management Committee, Cattaraugus County and Chautauque County, Northwest Communities and City of Buffalo. The NEST planning unit had a total population of 428,688 per the 2015 US census data. It is primarily suburban with denser areas closer to City of Buffalo and becomes increasingly rural further northeast and south the City.

Built space is primarily residential and commercial characterized by retail and office space. While much of NEST is rural/agricultural in nature, over time suburban sprawl has transitioned some formerly rural space into housing and commercial development.

All municipal solid waste generated within the planning unit is sent to privately owned disposal facilities. The majority of municipalities either contract with a private firm for curbside garbage and recycling pickup or use municipal staff and equipment for collection. The towns of Clarence, Concord and Hamburg have residents contract directly for their curbside garbage and recycling pickup. Some yard waste and debris is composted at municipal or privately owned and operated sites. There is minimal recycling of food waste. Hazardous and semi-hazardous materials are captured and diverted through County drop-off opportunities. Businesses, construction firms and institutions contract directly with private firms for their recycling, construction & demolition debris, special waste and general waste disposal. Numerous private entities accept donated textiles and household goods.



# PLAN PURPOSE

The purpose of this plan is to:

- Serve as a framework to coordinate solid waste management in the NEST Solid Waste Management Board.
- Establish solid waste goals and methods for monitoring progress towards the goals.
- Satisfy the NYDEC legal requirements for solid waste planning and comprehensive recycling analysis.

Achieving the NYSDEC 2030 goal of reducing waste generation to 0.60/lb/person/day requires building a bridge from the current waste management system to a more circular economy focused on productively managing materials that would otherwise become waste. This will require development of reuse alternatives, redirection of resources and ongoing education and outreach.

The Plan objectives are to increase education and outreach, strengthen and expand existing programs, create a focus on diverting organics, and partner with businesses who are creating reuse options. The Plan focuses on coordinating activities and sharing services to achieve these goals.

## Where did household waste from this planning unit go in 2017?

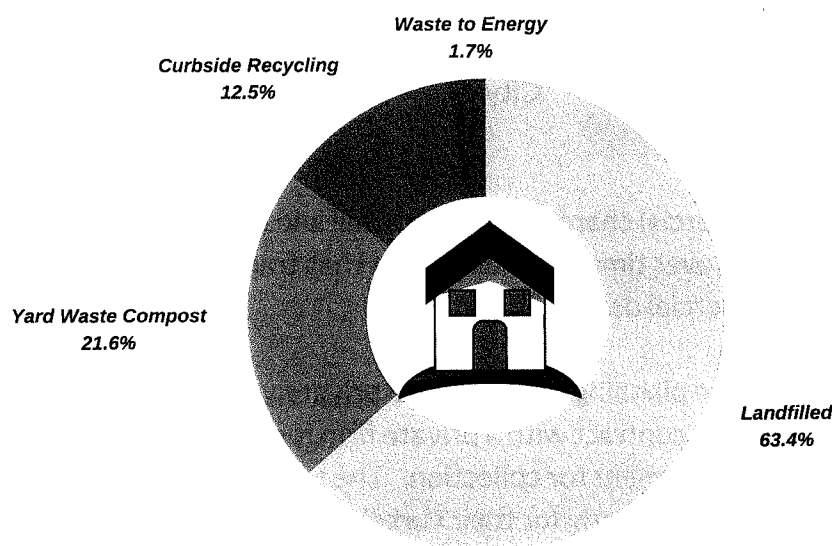

Disposition of 243,506 tons of Household Waste Generated in the Planning Unit in 2017

This data is derived from annual reporting to describe the flow of solid waste at the municipal and county level.

- Reports from solid waste facilities detailing materials sent to a facility by each County.
- Reports from municipalities detailing the amount and composition of the municipal solid waste (MSW) stream collected from households.

EXE  
PL  
This  
regu  
wast  
goals  
Erie  
supp  
colle  
outr  
The  
• Mc  
• Di  
• Re  
recy  
• Cc  
• D  
• B  
• Ne  
• Pu  
M  
De  
rec  
inc  
bet  
cle  
pla  
• C  
r  
• C  
e  
• S  
c  
• P  
o  
o  
• E  
Y

## PLAN GOALS

This plan describes the current waste management systems along with their legal and regulatory frameworks. It identifies strategies for management and minimization of the waste streams during the 10 year planning period. The plan addresses the local response to goals set forth in the NY State Solid Waste Management Plan titled *Beyond Waste*.

Erie County supports the Board by completing regulatory reporting, providing contractual support to member municipalities, supporting infrastructure for special waste collections, collecting data for good decision making and providing evidence-based education and outreach programs and materials.

The Plan Objectives are to:

- **Make Less Waste**
- **Divert Organics** from the landfill
- **Recycle Right** by increasing participation in recycling while reducing contamination in recycling streams
- **Continue to offer Keep it Out** programs to divert special/large wastes from landfill
- **Develop a Response Ready** local disaster debris management plan
- **Be Team Players** by participating in and supporting Statewide priorities and campaigns
- **Next Generation** outreach to kids and families
- **Public Private Partnerships**

## MAKE LESS WASTE

Decreasing the amount of solid waste generated requires education, legislative supports, financial incentives, and systems to manage various materials before they become waste. These efforts require a clear consistent focus on goals and outcomes. The planning unit will be focused on:

- Connect businesses and residents with available resources.
- Conduct education and outreach about the environmental impacts of single use items.
- Support product stewardship as part of the circular economy.
- Promote and partner with entrepreneurs and organizations that provide reuse and repair opportunities.
- Explore disposal fee structures such as Pay As You Throw (PAYT) to incentivize less waste production.



### Average Household Waste Footprint Lbs/ Person/Day

- 2.33 pounds of waste generated for landfill disposal or waste to energy
- 1.16 pounds recycled
- 0.40 pounds of composted materials, mostly yard waste

Data generated using NYSDEC tool & 2015 national data provided by USEPA

## DIVERT ORGANICS

Food waste diversion actions will be jump started by the Food Donation and Food Scrap Recycling Act. The act requires businesses and institutions that create large quantities of food waste to minimize food waste through planning, maximizing the amount of food which is safely sent to feed hungry people, and divert all organic waste from the landfill. These requirements should help to create the infrastructure for expanding or creating private composting facilities as well as anaerobic digesters are already operating and have additional capacity. To increase food diverted from landfill requires encouraging and supporting home composters while addressing cost and transportation barriers to expand services for commercial entities and institutions, and add residential pickup services. Pilot projects will help determine what types of services will be supported by the local market.



## KE

The hanc texti whit  
• Cor diffe  
• Cor mun  
• Ex supp  
• Ex  
• Ser  
• Ex  
• Ex  
• Co  
Cont

## RECYCLE RIGHT NY - MORE & LESS

The market for reuse of recycled materials has destabilized, in large part, due to changes in policies in China. This has resulted in decreasing demand for currently accepted materials, new restrictions on what items can be recycled and requirements for a cleaner recycling stream. Consequences include higher fees for managing recycling and more restrictions on acceptable items for curbside programs. The planning unit is responding by leading education and outreach to explain the changes to residents while encouraging more recycling of the right things with less contamination. These activities will be supported by:

- Creating a solid waste board web-site.
- Developing a county-wide standard visual menu & presentation on what goes curbside, drop off, or trash bin.
- Promote statewide campaigns targeting contamination including #RecycleRightNY.
- Give curbside feedback to residents through Oops tag pilot programs.
- Find a new place for glass possibly by expanding use of bottle bill returnables.

**AVOID WISHCYCLING**  
(putting things in your recycling cart that don't belong)



## RE

Even muni the N may appr remo

## TE

Erie state  
• C  
• P  
• R  
• G  
• T

## KEEP IT OUT PROGRAMS

The member municipalities expend considerable time and money handling and disposing of other waste materials including furniture, textiles, electronic waste, household hazardous waste (HHW), bulk white goods, and latex paint. The Board will assist by:

- Connecting people to reuse opportunities and safe disposal for different goods.
- Continuing the shared services e-waste contract used by municipalities to hold collection events.
- Expanding the number of one-day HHW collection events and supporting a permanent HHW collection facility.
- Exploring feasibility and funding for a mattress recycling program.
- Seeking opportunities and markets for recycling carpet.
- Exploring feasibility for curbside pickup of textiles.
- Exploring reuse opportunities for some C&D waste.
- Continuing to offer hazardous waste collection programs for Conditionally Exempt Small Quantity Generators.



## RESPONSE READY

Even smaller scale natural disasters create debris. Erie County will work with municipalities to create a community action plan for managing disaster debris using the NYSDEC Disaster Debris Management toolkit as a guideline. Planning activities may include stand-by emergency debris removal contracts for disposal services, pre-approved temporary staging areas, and educational materials for safe residential removal of building materials and yard debris.

## TEAM PLAYERS

Erie County on behalf of the member municipalities will continue to participate in statewide initiatives and support legislative solutions through:

- Continued involvement in NY State Association for Reduction, Reuse and Recycling.
- Participation and leadership in regional and statewide conferences.
- Participation in statewide campaigns including #RecycleRightNY.
- Supporting state-level stewardship efforts and expansion of the bottle bill.
- Coalitions including the local Bring Your Own campaign.





## NEXT GENERATION

School-aged children often lead reduce, reuse and recycling efforts in their households. Erie County and the municipalities will continue to provide education and outreach to schools by attending science fairs and environmental days, speaking at Earth Day events and sponsoring contests with recognition for student led solutions. For example, The Pollution Prevention through Recycled Art program educates art and science teachers about the impacts of pollution and inspires hundreds of local students to create art out of plastic pollution.

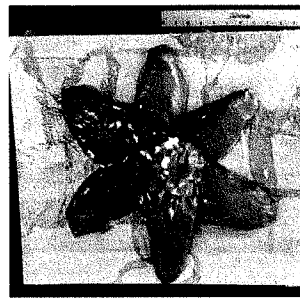
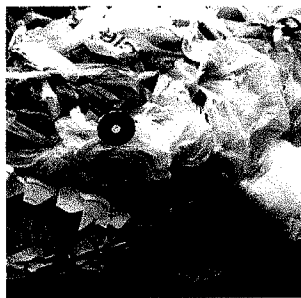
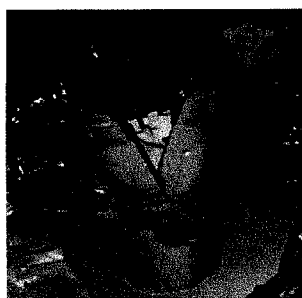

## PUBLIC/PRIVATE PARTNERSHIPS

The solid waste system in Western New York is facilitated by the private sector through privately owned facilities and equipment. This includes reuse operations taking household goods, textiles and electronics to be reused or repurposed before entering the waste stream.

Entrepreneurs and innovators in the private sector have the potential to find value in materials and therefore improve management. Triad Recycling is a local example of a private company which partners with many producers to establish recycling programs for specific streams that are typically difficult to recycle.

Creating an environment conducive to these enterprises is critical for successfully changing the waste system. This is particularly true as we look to implement new techniques and systems.



Photograph of wind turbines in Lackawanna NY

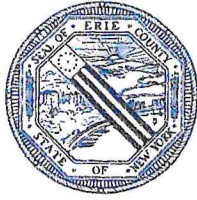

# ERIE COUNTY LEGISLATURE

HON. JOHN J. MILLS  
11<sup>TH</sup> DISTRICT LEGISLATOR  
MINORITY LEADER

February 8, 2024

Supervisor Jason Keding  
5458 George Drive  
Hamburg, NY 14075

Dear Supervisor Keding,

Congratulations on being named President of the Association of Erie County Governments for 2024. I am grateful for your continued willingness to serve. I know your skills, knowledge, and passion for public service will be a great asset to the Association. I wish you and the Association continued success as you move forward.

If I may be of service to you regarding county issues, please contact my office at (716) 858-8850 or [John.Mills@erie.gov](mailto:John.Mills@erie.gov).

Sincerely,

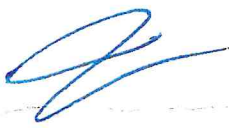
  
Minority Leader John J. Mills  
Erie County Legislator, District 11



# Western New York Southtowns Scenic Byway

## Buffalo Bills Partnership Proposal



### Information Sheet

The Western New York Southtowns Scenic Byway (the **Byway**) is requesting to have two information “kiosks” at the new Buffalo Bills Stadium in Orchard Park. The Byway is seeking to partner with the Bills, the Buffalo Bills Stadium Corporation, Erie County, and the Community to construct these kiosks on stadium property.

Since the early millennium, the Byway has been a proponent of the many recreational and cultural opportunities that exist along its 108-mile loop route winding from Orchard Park to Ellicottville. Its main spine, the US 219, is the primary access for the Southern Tier and Northern Pennsylvania for travelers to Buffalo Bills games. But there remain countless opportunities for the urban centers of Buffalo, Rochester, and Toronto to access the Byway and its resources. With the support of all towns and both counties through which it traverses, the Byway is an attractive vessel for increased economic activity in the underserved and lower-income areas it encompasses.

**It is quite natural then, that the development of a state-of-the-art stadium just two miles off the Byway route include information to allow visitors to explore the venues, attractions, and natural resources that southern Erie and Cattaraugus County offer.**

A partnership that included kiosks on stadium property affords such an opportunity! The Byway is seeking both cooperation and proper funding to achieve this goal. We are a small 501-3(c) organization that have been proud stewards of the Byway since its inception.





# ABOUT THE PROPOSED KIOSKS

We request that the proposed Byway Kiosks be strategically located: one between the parking lots and the stadium, and one in the vicinity of the Buffalo Bills store. We have developed a conceptual design of a kiosk, which could consist of multiple signboard panels to convey various destination information to the football fan. The concept design complements the architecture of the Stadium under construction. Messaging will be consistent with our Byway mission, the themes which are readily found on our sixteen Byway interpretive signs located along the corridor. The Bills will be entitled to review all signboard messages.

**Other Considerations:**

- Construction via stadium contract change order and in accordance with the MWBE contracting goals established.
- Maintenance under the Stadium agreement
- The Byway is seeking funding from the Stadium Agreement's **Community Benefit Oversight Committee**. The Byway anticipates a match to the funds received.

**Figure of Proposed Byway Kiosk at the new Stadium**



# REGIONAL TOURISM, ECONOMIC GROWTH, and ACTIVE RECREATIONAL OPPORTUNITY

- The foothills of the Allegheny Mountains and its watercourses are breathtaking and invite all tourists from Buffalo, Rochester, Pennsylvania, and Ontario to explore!
- The Byway provides:
  - activities for people of all ages, demographics, and abilities
  - Significant cultural tourism
  - Connection to regionally significant rail trails
  - Outdoor recreation activities: hiking, biking, mountain biking, picnicking, camping, downhill skiing, cross country skiing, snowmobiling, snow shoeing, sledding and tobogganing, zip lining, fishing, kayaking and canoeing.
  - Agritourism: maple syrup production, farm to table restaurants and produce stands, dairy products.
- The Chautauqua Allegheny Region which includes Cattaraugus County accounts for about 1% of NYS Tourism dollars (underserved).
- Several underserved Byway Towns and Villages (businesses) benefit economically from recreational and cultural tourism
- The table below indicates the economic climate:



Location	Median Household Income	Persons in Poverty (%)
Erie County	\$68,014	13.3
Village of Springville	\$55,305	15.3
Cattaraugus County	\$56,899	16.2



# MAKE-UP and MISSION OF THE WESTERN NEW YORK SOUTHTOWNS SCENIC BYWAY

- Our Mission: To Promote economic development and community pride through the thoughtful stewardship of the natural, scenic, cultural, historic and recreational resources of the byway region.
- The Byway encourages people from all demographic and physical abilities to become active in its scenic outdoors.
- The 108-mile Byway includes Towns of: Orchard Park, Aurora, Boston, Colden, Concord, Ashford, and Ellicottville
- There are four Villages included: Orchard Park, East Aurora, Springville, and Ellicottville
- The Byway works with NYSDOT to maintain our Route Signs, and have developed an Interpretive Sign Program (16 signs)
- Key Byway Routes include US 219, NY 242, NY 240, and US 20A (see our Byway Map)



## THE BILLS AND THE BYWAY – IN SUMMARY

- The Proposed Byway Kiosks are needed to expand regional awareness of outdoor recreational and cultural opportunities.
- The new stadium provides a tremendous opportunity to grow on the Bills as a regional attraction, with an opportunity for their fans to learn about the Byway offerings!



Image Borrowed from Populous Architects; Not for Public use.



Sample of our Interpretive Sign Program



Western New York Southtowns Scenic Byway

[www.wnyssb.org](http://www.wnyssb.org)



# TOWN OF BOSTON

**COPY**



## TOWN OF BOSTON – RESOLUTION NO. 2023-41

### PROFESSIONAL SERVICES AGREEMENT FOR LENGTH OF SERVICE AWARD PROGRAM (LOSAP) POINT AUDIT

**WHEREAS**, the Town of Boston sponsors and funds a Length of Service Award Program (“LOSAP”) to incentivize and reward volunteer members of the fire companies that serve the Town; and

**WHEREAS**, the LOSAP program currently is funded at a level below what is recommended by the program’s actuaries, and the Town is reviewing its options to maintain a viable program, including potential modifications to the program; and

**WHEREAS**, the LOSAP actuaries recommend that in connection with reviewing the program, an audit of the service points awarded pursuant to the program should be completed; and

**WHEREAS**, the Town has obtained a proposal from the Pinsky Law Group, PLLC, to perform the required scope of work for a total fee of \$4,800;

### NOW THEREFORE BE IT

**RESOLVED**, that Town Board of the Town of Boston hereby authorizes the Town Supervisor to accept the proposed retainer agreement from Pinsky Law Group, PLLC, dated April 11, 2023, to perform an audit of the LOSAP service awards points for a flat fee of \$4,800.

On May 3, 2023, the question of the adoption of the foregoing Resolution was duly put to a vote on roll call, which resulted as follows:

	Yes	No	Abstain	Absent
Councilmember Cartechine	[ X ]	[ ]	[ ]	[ ]
Councilmember Lucachik	[ X ]	[ ]	[ ]	[ ]
Councilmember Martin	[ ]	[ ]	[ ]	[ X ]
Councilmember Selby	[ X ]	[ ]	[ ]	[ ]
Supervisor Keding	[ X ]	[ ]	[ ]	[ ]

  
Sandra L. Quinlan, Town Clerk





4311 East Genesee Street  
Syracuse, New York 13214  
(315) 428-8344  
(315) 475-8230 (fax)

Bradley M. Pinsky, Esq.

[bpinsky@pinskylaw.com](mailto:bpinsky@pinskylaw.com)

Nicole C. Pinsky, Paralegal

[npinsky@pinskylaw.com](mailto:npinsky@pinskylaw.com)

April 11, 2023

Town of Boston  
8500 Boston State Road  
Boston, New York 14025

**Re: Flat Fee Retainer: Service Awards Points Review**

Dear Town Supervisor:

This letter will summarize the proposed terms of our firm's assistance of your organization, on a flat fee basis, including the scope of services we will be providing, the agreed upon fee, and billing arrangements.

Scope of Engagement. We will assist the organization with a Service Awards Points Review to review one year of LOSAP point distribution.

Fee Arrangement. Our fee will be billed at the **flat rate of \$4,800.00**. Expenses, if any, are not included. **Fifty percent of the fee is required upon execution of this agreement, with the remaining fifty percent due upon completion of services.**

Should additional hourly services be requested or required, those are billed at \$290/hour in six-minute intervals.

Team System. The Pinsky Law Group, PLLC works in a team atmosphere. Therefore, it is possible that either Mr. Pinsky, an associate or a paralegal will perform work on one or more occasions.

Communication with Attorneys. We have experienced situations in which officers, members and employees of a client communicate with us on a matter. We cannot be expected to know which individuals are authorized and which are not authorized to communicate with us. We place the responsibility on you to caution your personnel from communicating with the attorneys without your authorization, as such fees will be billable to you as a client. Although we will try our best

to limit our communications with your authorized personnel, it is impossible for us to track all of our clients' authorized personnel. Thus, you must control your members'/employees' access to your attorneys and must agree to pay for the time incurred by us due to your personnel.

E-Mail Communication. You are warned that while email communication may be common, E-mails are not a protected means of communication between the attorney and client. Emails which are accessible to another person who is not a client are potentially discoverable. For instance, employer provided email addresses may not be protected. Pinsky Law Group, PLLC cannot possibly know which email addresses used by the client are accessible by other parties. You are responsible for ensuring that you do not email your attorney from an unprotected email address.

Term. The term of this Agreement shall be one year and may be renewed upon an oral agreement of both parties.

Termination of Engagement. Either of us may terminate the engagement at any time for any reason by written notice, subject, on our part, to the rules of professional responsibility. No such termination, however, will relieve you of the obligation to pay the legal fees owed to us for services performed and other charges owed to us through the date of termination. After the completion of our services on your behalf, changes may occur in applicable laws or regulations that could have an impact upon your future rights and liabilities. Unless you engage us after completion of the Project to provide additional advice on issues arising from the Project, the firm has no continuing obligation to advise you with respect to future legal developments.

Conclusion of Representation; Disposition of Client Documents. Following termination of our attorney/client relationship, any otherwise nonpublic information you have supplied to us that is retained by us will be kept confidential in accordance with applicable rules of professional conduct. At your request, we will return your papers and property promptly after receipt of payment for any outstanding fees and costs. Our own files pertaining to the matter will be retained by the firm. These firm files include, for example, firm administrative records; internal lawyers' work product such as drafts, notes, internal memoranda; and legal and factual research, including investigative reports, prepared by or for the internal use of lawyers. We will retain all remaining documents for a certain period of time, but we reserve the right for various reasons including the minimization of unnecessary storage expenses, to destroy or otherwise dispose of them within a reasonable time after the termination of the engagement.

Record Retention. Client files will be retained for a period of seven (7) years. Non-original documents may be scanned into our system with the paper file destroyed, before that date. Original documents such as contracts, signed papers, and other such files will be maintained for seven years, and then potentially destroyed before they are scanned. The client should not have the law firm maintain original documents. You are obligated to hold your original files, such as contracts, deeds, and abstracts of title.

Client Responsibilities. You agree to cooperate fully with us and to promptly provide all information known or available to you relevant to our representation. You agree to cooperate with us in all aspects of the representation. The failure to cooperate with us may result in the

inability of our attorneys to effectively represent you. Failing to return calls or provide us requested information may result in the inability of our attorneys to represent you. You also agree to pay in a timely manner our statements for services and expenses as provided above.

Organization as a client: We will be retained to represent the organization and not any individual in the organization. Our ethical duty requires us to provide our allegiance to the organization and not to any individual. Should any conflict arise between any commissioner, member, director, officer and the organization, the law firm at all times must represent the interests of the organization.

We look forward to working with you!

Very truly yours,

PINSKY LAW GROUP, PLLC

By:   
Bradley M. Pinsky

Agreed and Accepted this 4<sup>th</sup>  
Day of MAY, 2023

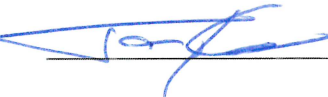
\_\_\_\_\_  
By:   
Title: SUPERVISOR





4311 East Genesee Street  
Syracuse, New York 13214  
(315) 428-8344  
(315) 475-8230 (fax)

November 13, 2023

Town of Boston  
Attn: Supervisor  
8500 Boston State Rd  
Boston, NY 14025

Dear Supervisor:

We have completed an in-depth review of the 2022 LOSAP program of the Town of Boston with regard to the Boston Fire Company.

#### Methodology

We reviewed every single piece of paper that you provided to us, which included:

- Drill sheets
- Call attendance sign in sheets
- Work details
- Lists of officer position

We then recalculated every single activity and created new point totals.

#### Drills

By law, drills must be two hours in length. Most of the drills failed to contain a start and end time. Any drill that did not verify that it was at least two hours in length *should* have been counted as a “Miscellaneous” detail. However, since this is the first review of your program of which we are aware, we gave credit for each drill unless it specifically listed the hours as being less than two hours. In that case, we moved the drill to the “misc” column and counted it there. In the future, every drill sheet must have the start and end time, or the drill credit should be denied.

#### LOSAP Points for Responses

It appears that partial points are being awarded for responses. This is not authorized. The response category is an “all or nothing” award, so either an individual is awarded 25 points or no points. As a result, some persons may have qualified that should not have qualified.

Officer point totals

There are two significant issues. First, some persons appear to have been given partial points for holding an office. LOSAP laws only permit an individual to receive credit if they have completed a full term of office. Partial points are not permitted.

Additionally, one of the categories originally adopted by the Town allows for the holder of a miscellaneous office to receive up to 5 points. This is not permitted and we should discontinue use of this category. Instead, if there are any missing categories, we should define which offices can receive points, and how many points.

Conclusion

We believe that a review of the 2023 points should be conducted to ensure that only those persons who have completed a full term of office receive credit, and those who did not meet the minimum percentage for call responses do not receive any credit.

Very truly yours,

PINSKY LAW GROUP, PLLC

By:   
Bradley M. Pinsky



4311 East Genesee Street  
Syracuse, New York 13214  
(315) 428-8344  
(315) 475-8230 (fax)

November 13, 2023

Town of Boston  
Attn: Supervisor  
8500 Boston State Rd  
Boston, NY 14025

Dear Supervisor:

We have completed an in-depth review of the 2022 LOSAP program of the Town of Boston with regard to the North Boston Fire Company, one of three fire companies in the Town's program. We have several strong suggestions to be considered for better accountability of the Program by this fire company.

Our primary concern is that your LOSAP program awards points in violation of the law. The issue is not something that the members are doing incorrectly. Instead, your LOSAP resolution impermissibly assigns points to categories in violation of the law. I discuss this below.

Interestingly, I did not notice these same issues with Patchin Fire Company.

#### Methodology

We reviewed every single piece of paper that you provided to us, which included:

- Drill sheets
- Call attendance sign in sheets
- Work details
- Lists of officer position

We then recalculated every single activity and created new point totals.

#### Generally

The sign in sheets are not always easy to determine who signed in. For that reason, the members' numbers should be circled as well as a signature added, to make sure the proper persons receive credit.

Additionally, in some instances there is just an “x” with no signature. It is impossible to determine if the person actually attended the event. Many of these are for meetings, and there is no reason why the person should not have signed in themselves.

Drills

By law, drills must be two hours in length. Most of the drills failed to contain a start and end time. Any drill that did not verify that it was at least two hours in length *should* have been counted as a “Miscellaneous” detail. However, since this is the first review of your program of which we are aware, we gave credit for each drill unless it specifically listed the hours as being less than two hours. In that case, we moved the drill to the “misc” column and counted it there. In the future, every drill sheet must have the start and end time, or the drill credit should be denied.

My drill points do not add up in most cases to what was awarded. It is possible that I am missing the drill sheets, but I would ask that you compile another copy of the drill sheets and recalculate. For now, however, the points do not add up.

	MY TOTALS	AWARDED
Rodney Carr	11	16
Sean Crotty	5	9
Thomas Edington	12	15
Justin Proudman	4	4
Zachary Walsh	5	12
Schott Gibbons	4	5
Ryan Laity	7	8
Beth Steward	2	3
William Gross	8	10
Hannah Howei	10	10
John Seymour	12	14
Joe Marchinda	18	20
Gabe Frascella	10	14
Kenneth Manista	14	17
Louis Manista	11	13
Derek Wieckowski	15	20
John Bruan	12	13
Donald O'Bryant	16	20
Ronald Pigeon	3	3
Ernie Rauch	12	17
Tom Ricotta	10	15

Justin Smolinski	7	12
Warran Skinner	11	14
Karne Wieckowski	16	19
Jeff Knowles	16	20
Chris Muraco	1	1
Kevin Steward	3	5
Bob Pollinger	13	16
Gene Wieckowski	10	11
Daryl Kibler	10	14
Andy Lickfield	7	9
Paul Meller	11	14

Elected Position Points

This category has serious issues.

First, your LOSAP resolution awards 5 points for “Fire Police”. This is not authorized under the law. The definition of “Elected or appointed position” means “line officers, department or company officers and president, vice president, treasurer and secretary of a fire company or department.” Fire Police are not elected officers of the fire department, as this term is defined.

You also award points for “TK/EMS”. I am not sure what this is for, and five members are receiving five points each, but this also seems incorrect and does not appear to be an actual office.

It appears that points were awarded for attending committee meetings or serving as a chair of a committee (3 points), but this is not permitted under this category. Instead, persons are to be awarded 1 point for each committee meeting.

Committee points

Discussed immediately above. Attendance should be recorded under Miscellaneous as should serving as chair. There is no officer position for serving as a chair of a committee. You cannot award three points as is occurring.

The law provides: “Miscellaneous activities - maximum fifteen points. Participation in inspections and other activities covered by the volunteer firefighters' benefit law and not otherwise listed - one point per activity.”

Additionally, there are no attendance/sign in sheets for committee meetings. Did I miss the sheets?



### Call Sign in Sheets and Call Attendance

The law permits the fire department to utilize two separate “denominators”, being one for “fire” calls and one for “rescue/EMS” calls. You may consider splitting the calls between EMS/Rescue and Fire instead of combining the categories. Persons could then attain 25 points in each category if they met the minimums.

### Training Courses

The training certificates mostly did not include the number of hours. I could not locate hours for the courses, so I could not determine if the points were assigned correctly. Hours must be noted on the certificates so that a proper calculation can be performed.

### Conclusion

The most serious issues to address for 2023 are stated above but should be corrected before 2023 points are awarded.

Very truly yours,

PINSKY LAW GROUP, PLLC

By:   
Bradley M. Pinsky



4311 East Genesee Street  
Syracuse, New York 13214  
(315) 428-8344  
(315) 475-8230 (fax)

November 13, 2023

Town of Boston  
Attn: Supervisor  
8500 Boston State Rd  
Boston, NY 14025

Dear Supervisor:

We have completed an in-depth review of the 2022 LOSAP program of the Town of Boston with regard to the Patchin Fire Company, one of three fire companies in the Town's program. We have several strong suggestions to be considered for better accountability of the Program by this fire company. However, let us first note that although our point totals and calculations differ in some respects from those of the fire company, our results were the same. In other words, only those persons who should have qualified did so, and those who did not qualify were correctly denied an award for the year.

#### Methodology

We reviewed every single piece of paper that you provided to us, which included:

- Drill sheets
- Call attendance sign in sheets
- Work details
- Lists of officer position

We then recalculated every single activity and created new point totals.

#### Drills

By law, drills must be two hours in length. Most of the drills failed to contain a start and end time. Any drill that did not verify that it was at least two hours in length *should* have been counted as a "Miscellaneous" detail. However, since this is the first review of your program of which we are aware, we gave credit for each drill unless it specifically listed the hours as being less than two hours. In that case, we moved the drill to the "misc" column and counted it there. In the future, every drill sheet must have the start and end time, or the drill credit should be denied.

Additionally, certain “drills” did not appear to be valid drills, such as “hall cleaning” and “front hall”. Instead, that should be moved to the “misc” category.

#### Call Sign in Sheets and Call Attendance

Only eight (8) members achieved the 10% required by statute to receive 25 points for this category. Your results were the same as ours, but the methodology and numbers were different. First, the total number of calls that you utilized was 174. However, we had only 151 call sheets. Under either calculation, however, the results were the same and the same 7 person qualified. No other persons would have qualified using the lower call number, and no persons qualified who should not have qualified if the lower call number was utilized.

An additional suggest is as follows: The law permits the fire department to utilize two separate “denominators”, being one for “fire” calls and one for “rescue/EMS” calls. Forty-one (41%) percent of the calls are “fire” calls and fifty-nine (59%) of the calls are EMS calls. The sign in sheets have check boxes for the type of call, but provide five (5) different categories. For any call, there should be a choice of only “fire” and “Rescue/EMS”. That way, we can determine who responded to which type of call.

Additionally, the ten percent requirement to make calls would be reduced for each category, such that a member would only have had to attend 6 or 7 EMS calls and 8 or 9 fire calls. Additionally, if the member achieved ten (10%) from both categories, they would obtain 25 points for each category, being 50 points.

The methodology used by the Company now requires the individual to respond to 15 calls. Although this is not a significant response number in and of itself, the methodology I propose would allow those persons who respond only to fire or EMS calls, but not both, a better opportunity to achieve their points.

#### Missed opportunities

It appeared that no volunteer was provided any calls for taking any training courses. Additionally, the “fire prevention” line was never used, but we saw two drills that qualified as fire prevention. Since they did not meet the two hour test, we moved them to “fire prevention” for which someone could gain 5 points.

We did not see any points given for “standbys”, such as if the department was staffing a vehicle for some reason. Details such as Halloween details where the vehicles are staffed would qualify as such an event.

We did not see any committee meetings included under the “misc” category.

We did not see anyone attending any formal class of instruction, although one person appeared to take the “Firefighter II” class, but we only saw a drill sheet and not a class certificate. Classes are not to be given drill credit, but are to be given training credit as per your program.

Conclusion

Although the calculations worked out correctly such that only those persons who should have qualified did qualify, and none of the persons who did not qualify should have qualified, the documentation could be much better. Primarily, drill sheets should be given credit only for drills lasting two hours. Otherwise, such events should be considered “misc” activities. Calls probably should be split between EMS/Fire. Finally, we question if other activities were conducted that could have been eligible for points.

Very truly yours,

PINSKY LAW GROUP, PLLC

  
By: \_\_\_\_\_

Bradley M. Pinsky

# OFFICE OF THE NEW YORK STATE COMPTROLLER

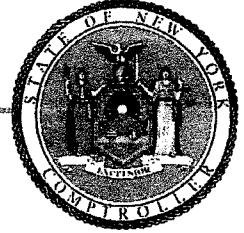

Thomas P. DiNapoli, State Comptroller

## ANNUAL REPORT ON REVENUES AND EXPENDITURES OF FOREIGN FIRE INSURANCE PREMIUMS

(See Instructions on Reverse Side)

For the calendar year January 1, 2023 - December 31, 2023

Name of Entity: Patchin Volunteer Exempt Fireman's Benevolent Assoc Fire District # (if known) \_\_\_\_\_ County Erie  
Address: 8333 Boston State Road City/Town/Village: Boston ZIP 14025  
Type:  Fire Department  Fire Company  Benevolent Association  
Town or City Where Located: Boston Village Where Located (if applicable) \_\_\_\_\_  
Fire Protection District Where Located (if applicable) Boston  
Fire District Where Located (if applicable) \_\_\_\_\_

	AMOUNT
Balance: (as of 1/1/23):	\$ <u>64,602</u>
Revenues: Foreign Fire Insurance Premiums Only:	
<u>Source</u> (list separately if received from multiple sources)	
_____	\$ <u>6347</u>
_____	\$ <u>50</u>
_____	\$ _____
_____	\$ _____
Interest on investment of Foreign Fire:	\$ <u>5</u>
Total Revenues:	\$ <u>6402</u>
Total Balance and Revenues:	\$ <u>71,004</u>
Expenditures: (please add separate sheet if necessary)	
_____	\$ _____
<u>9 claims</u>	\$ <u>7862</u>
_____	\$ _____
Total Expenditures:	\$ <u>7862</u>
Balance (as of 12/31/23)	\$ <u>63,142</u>

I, William Schwab certify that this report is a true and accurate statement of the revenues and expenditures of Foreign Fire Insurance premiums for the calendar year ended 2023.  
(Signature): William Schwab (Title): Treasurer  
(Print Name): William Schwab (Telephone Number) \_\_\_\_\_

**Please e-mail, fax or mail report to:**  
[afritie@osc.ny.gov](mailto:afritie@osc.ny.gov)  
Fax: 518-486-3146  
Office of the State Comptroller  
Division of Local Government and School Accountability  
Data Management Unit, 12-8-C  
110 State St.  
Albany NY 12236-0001  
Telephone: 1-866-321-8503 or (518) 408-4934 if calling locally





**National Fuel**

Engineering Services

February 14, 2024

Town of Boston  
8500 Boston State Road  
Boston, NY 14025  
Supervisor

FEB 22 2024 @10:25

Re: Highway & Municipal Construction Projects

Dear Sir or Madam:

**PLEASE ADVISE OF PUBLIC IMPROVEMENT PROJECTS IN YOUR JURISDICTION.**

National Fuel Gas is in the process of planning pipeline replacement projects for 2024-2025. To plan for replacements resulting from public improvement projects, we are asking that you provide us information on projects planned in your jurisdiction. It is important that we receive information on projects involving:

- Grade changes within road right-of-way
- Drainage
- Full depth road construction
- Paving and restoration

These projects may involve replacement of National Fuel Gas facilities. When these facilities are involved, we usually require 6 months advance notice to design, bid, and construct. When environmental permitting is required, it may substantially prolong the project schedule.

Please provide a preliminary list of your planned projects, anticipated scope, and estimated start dates to Andrew Gilbert, Utility Design Engineer. We understand that many times projects are delayed, and others are added based on funding and area needs. As your plans develop, please send us digital copies of construction designs so that we may evaluate our involvement and identify any conflicts. When Mill and Pave projects do not involve a direct conflict, National Fuel may be able to avoid future pavement cuts by replacing aging facilities prior to resurfacing.

Our goal is to coordinate pipeline replacement projects with municipal projects so that we may relocate our facilities in advance of your construction when warranted. The result will be fewer delays and conflicts for your contractors and will help provide safe and uninterrupted gas service to your community.

If you are planning a pre-design survey, submit a One-Call design ticket, and provide project information in the remarks section. Identifying gas line locations on your plans can be extremely helpful to your contractors in improving safety and avoiding charges for damaging underground gas facilities.

As an additional resource to utilize early in design of any construction projects, the Pipeline and Hazardous Materials Safety Administration (PHMSA) collects data from transmission pipeline operators and displays GIS pipeline information for transmission facilities **ONLY** on their NPMS Public Viewer. When transmission facilities are involved, National Fuel has additional requirements that need to be considered that may impact project scheduling and costs. This GIS database can be found at <https://pvnpm.phmsa.dot.gov/PublicViewer/> and is a free tool to use to assist in identifying

if transmission facilities exist near your project limits during the design phase. Please note that this is **NOT** to be considered as a substitute for the 811-call procedure and does **NOT** identify non-transmission facilities.

While highway infrastructure, municipal utilities and pipelines can safely coexist, it is extremely important to thoroughly consider natural gas pipelines when developing building or construction plans. Please visit National Fuel's Pipeline Safety website at <https://www.nationalfuel.com/pipeline-storage/about-pipeline/pipeline-safety/> for information on designing and constructing facilities near natural gas pipelines, including;

- The Pipeline and Informed Planning Alliance (PIPA) recommended practices for property developers and planning boards on building safely near natural gas pipelines.
- National Fuel's encroachment manuals, which explain right-of-way agreements, encroachment agreements, construction requirements and other valuable information for planners and developers looking to begin the design phase.

Prior to construction, it is the Excavator's responsibility to contact the One-Call Center (Call 811) which in turn notifies National Fuel of planned excavation in proximity to our natural gas pipelines and other facilities. This enables us to mark the location of those facilities in advance of excavation.

To ensure worker and public safety during construction, National Fuel is providing guidance for working around gas facilities in this correspondence. Enclosed are a "Summary of Excavator Responsibilities" and a "Typical Gas Line Crossing/Open Trench Detail." For excavation and safety training materials, please refer to the National Fuel Pipeline Safety webpage for additional information and links to training materials on excavation safety, including the UDig NY website at <https://udigny.org/safety-training/safety-videos/> for their library of safety videos. We urge you to share this information with your contractors and inspectors by including this information in your bid documents and construction specifications. We also ask that you encourage your inspectors to enforce proper excavation practices with your contractors during construction.

**Enforcing proper excavation practices around gas pipelines is especially important considering an incident in January of 2011, in Horseheads NY. There, improper backfill procedures following the installation of municipal sewer and water facilities caused a pre-existing gas pipeline to crack. The resulting leak ignited, resulting in a fatality and two injuries.**

**In another case, a deadly residential home explosion took the life of a child two decades after crews installed a sewer line using improper excavation procedures. In 2016, an incident occurred in Dallas, TX that involved 3-separate residential fires and/or explosions during a three-day period. The cause was found to be a leak resulting from a crack of a 2" steel main installed in 1946. The cracked resulted from a dent caused by a sewer replacement project in 1995. The guidance attached to this letter is designed to improve excavation practices so that the circumstances that led to these incidents can be avoided.**

Please contact Andrew Gilbert regarding project coordination.

Sincerely,

*Doug Long*

Doug Long  
N.Y. Lead District Engineer  
longd@natfuel.com  
(716) 857-7946

## **Summary of Excavator Responsibilities**

See One-Call regulations for details ([www.Call811.com](http://www.Call811.com)).

1. Notify the One-Call Center (**Call 811**) in accordance with regulations. In Pennsylvania, notification must be made not less than 3 nor more than 10 business days prior to commencing excavation work, and in New York this is 2 to 10 full business days prior to starting any work that might be considered an excavation or demolition. Postponing the job will likely require re-notification to the One-Call Center. Furthermore, if the job site becomes inactive, call to have the specific work area remarked prior to restarting the work.
2. Designating the dig site in white will aid in the timely marking of underground facilities. Pre-marking proposed facilities in white may be required.
3. If work is to be performed at multiple sites or over a large area, take reasonable steps to work with facility owners so that they may locate their facilities. Limit the size of each ticket. Using reasonable start dates for individual tickets facilitates getting the proper areas marked when needed.
4. In Pennsylvania, if a project involves more work than can be described on a single locate request (i.e., 1,000ft in length or intersection to intersection, whichever is greater) it shall be called in as a complex project notification.
5. After commencement of excavation or demolition work, the excavator is responsible for protecting and preserving the staking or marking until excavation or demolition work in the area is complete. If necessary, call the One-Call Center to have the lines remarked.
6. Where an underground facility has been staked, marked, or otherwise designated, verify the precise location, type, size, direction of run and depth of the underground facility. Use prudent techniques such as vacuum excavation or hand-dug test holes, to verify the precise location of facilities. It is best to verify prior to excavating in the general area, but verification must be done prior to excavating in the tolerance zone. Once the precise location of underground facilities has been verified, continue to exercise due care within the tolerance zone. Call the facility owner if a marked facility cannot be found or the One-Call center if an unmarked facility is discovered.
7. Inform each equipment operator of the information obtained from facility owners. Plan the excavation or demolition to avoid damage to or minimize interference with a facility owner's facilities in the construction area.
8. Consult the facility owner if:
  - a. Excavation or demolition work requires temporary or permanent interruption of a facility owner's service. Such interruption must be coordinated with the affected facility owner in all cases.
  - b. A facility is exposed or undermined. The excavator must provide support and mechanical protection for facility owner's lines at the construction site during excavation or demolition work, including during backfilling operations.
9. Report immediately to the facility owner any break, leak, dent, gouge, or other damage to the facility owner's lines made or discovered during excavation or demolition work. Including, damage to pipeline coatings, locating wire and cables for cathodic protection.
10. In the event of an emergency involving danger to life, health, or property as a result of damage to an underground facility containing gas or liquid petroleum products or as a result of an electrical short or escape of gas or hazardous liquids, the excavator shall:
  - a. Proceed to evacuate his or her employees and all other endangered persons from the immediate vicinity to the best of his or her ability. Do not use any mechanical or electrical equipment (including cellphones) in the area.
  - b. Immediately contact 911 and the Facility Owner, reporting the exact location, nature of the emergency and type of underground facility damaged.

**THE NATIONAL FUEL GAS COMPANY EMERGENCY NUMBER IS:  
1-800-444-3130  
24 hours/day, 7 days/week**



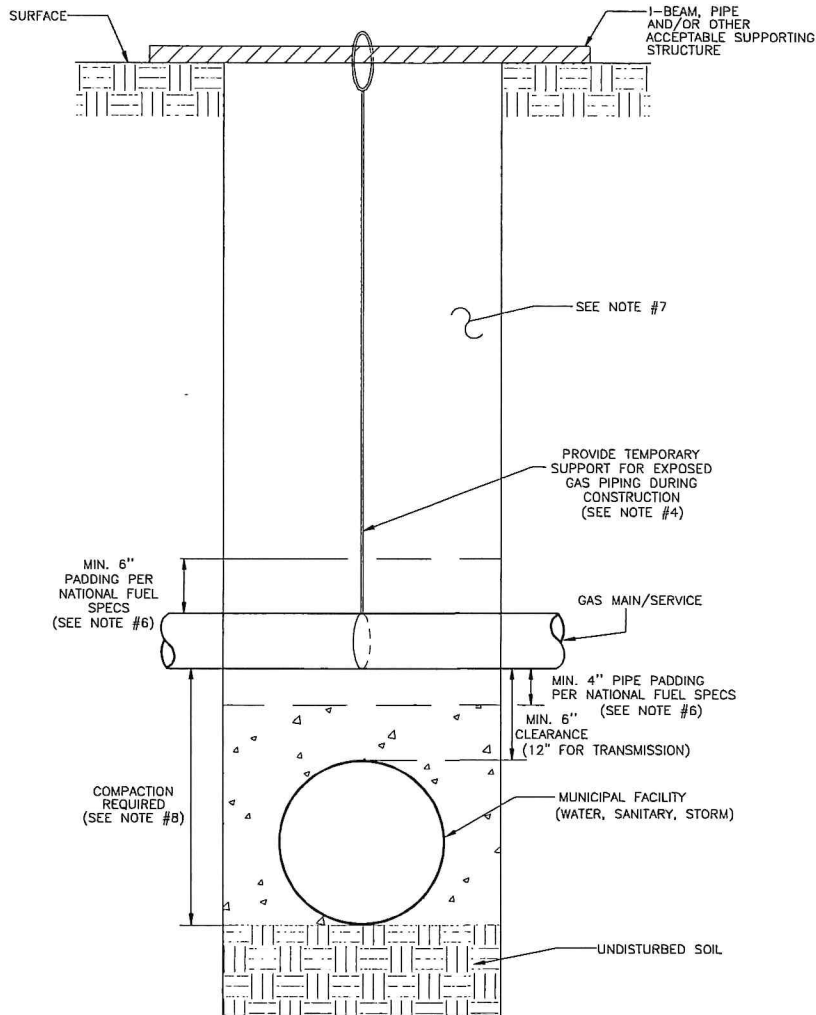

TYPICAL GAS LINE CROSSING OPEN TRENCH DETAIL

NOT TO SCALE

### NOTES

1. PRIOR TO ANY EXCAVATION WORK, DAMAGE PREVENTION LAWS REQUIRE PERSONS TO MAKE CONTACT WITH THE APPROPRIATE ONE-CALL SYSTEM BY CALLING 811 OR IN NEW YORK 1-800-962-7962/ IN PENNSYLVANIA 1-800-242-1776.
2. IF A NATURAL GAS FACILITY IS DAMAGED, RESULTING IN A RELEASE OF NATURAL GAS, IMMEDIATELY CALL 911 AND THE NATIONAL FUEL EMERGENCY NUMBER 1-800-444-3130.
3. IF A NATURAL GAS LINE IS SCRATCHED, GOUGED, DENTED, PULLED, OR BOWED DURING EXCAVATION WORK OR THE PROTECTIVE COATING IS DAMAGED, IMMEDIATELY CALL THE NATIONAL FUEL EMERGENCY NUMBER 1-800-444-3130 SO THAT WE CAN INVESTIGATE AND REPAIR ANY DAMAGE THAT COULD AFFECT PUBLIC SAFETY. SEEMINGLY INCONSEQUENTIAL DAMAGE CAN HAVE A MAJOR IMPACT AND CAN POTENTIALLY RESULT IN A FUTURE PIPELINE FAILURE.
4. NATIONAL FUEL REQUIRES THAT EXCAVATORS SUPPORT OUR FACILITIES IF EXPOSED DURING CONSTRUCTION. THE EXCAVATOR SHALL PROVIDE SUCH SUPPORT IN ACCORDANCE WITH GENERALLY ACCEPTED ENGINEERING PRACTICES. SUPPORT MUST BE MAINTAINED THROUGHOUT CONSTRUCTION AND BACKFILL OPERATIONS. THE SUPPORT SYSTEM SHALL PROTECT THE GAS FACILITIES FROM SETTLEMENT, TRAFFIC AND HEAVY LOADS OR FORCES. CONTACT NATIONAL FUEL FOR SUPPORT RECOMMENDATIONS AND INSPECTION WHERE GAS PIPING WILL BE EXPOSED FOR A LENGTH OF 15' OR GREATER, OR WHENEVER A COUPLING OR FITTING IS EXPOSED.
5. UNDERGROUND UTILITIES AND OTHER STRUCTURES PLACED NEAR NATIONAL FUEL FACILITIES MUST MAINTAIN A MINIMUM CLEARANCE OF 12" FOR TRANSMISSION PIPELINES AND 6" FOR DISTRIBUTION MAINS AND SERVICES. ANY METALLIC STRUCTURE PLACED NEAR STEEL PIPELINES REQUIRES THE INSTALLATION OF AN ELECTRIC TEST STATION.
6. BACKFILL MATERIAL AROUND NATIONAL FUEL GAS FACILITIES SHALL BE CLEAN DIRT, FREE OF SHALE OR SHARP STONES. ROUND STONES SHALL BE NO LARGER THAN 1" IN DIAMETER. ACCEPTABLE BACKFILL MATERIALS ARE:
  - A. SAND (SAND IS THE PREFERRED MATERIAL WHERE WASHOUT IS NOT LIKELY).
  - B. STONE "SCREENINGS" (LIMESTONE) ALL PASSING:
    - 100% PASSING THE NO.40 SIEVE
    - 70% PASSING THE NO.200 SIEVE
  - C. GRAVEL (A MODIFIED SIDEWALK MIX) OF A 50/50 BLEND OF NO.1A ROUND GRAVEL AND SAND.
  - D. NO.1A ROUND GRAVEL.
7. FILL MATERIAL BEYOND THE SELECT BACKFILL SHALL BE FREE OF LOGS, CINDERS, STUMPS, SKIDS, BRUSH OR ROCKS LARGER THAN 12 INCHES.
8. BACKFILL MATERIAL BENEATH AND AROUND ANY UNDERGROUND GAS FACILITY SHALL BE PROPERLY COMPACTED IN ACCORDANCE WITH GENERALLY ACCEPTED ENGINEERING PRACTICES.
9. HEAVY LOADS AND EXCESSIVE FORCES SHALL NOT BE IMPOSED ON GAS FACILITIES AT ANY TIME DURING CONSTRUCTION OR BACKFILLING OPERATIONS.
10. #10 OR #12 LOCATING WIRE IS BURIED ALONG SIDE MOST PLASTIC GAS MAINS AND SERVICES. HEAVIER CABLES (PART OF CATHODIC PROTECTION SYSTEMS) MAY ALSO BE FOUND NEAR SOME STEEL PIPE FACILITIES. IF ANY WIRE OR CABLE IS DAMAGED IT MUST BE IMMEDIATELY REPORTED TO NATIONAL FUEL.

 <b>811</b> Know what's below. Call before you dig.	 <b>national fuel</b> DISTRIBUTION CORPORATION	<b>TYPICAL GAS LINE CROSSING OPEN TRENCH DETAIL</b>			DRAWING NUMBER	
		<b>ENGINEERING</b> 6363 MAIN STREET WILLIAMSVILLE, NY 14221		DRAWN BY: T. NUGENT	CHECKED BY: M. PARKER	APPROVED BY: K. HOUSE
		DATE: 1/5/12	FILENAME: GASLINECROSSINGDETAIL.DWG			

**TOWN OF BOSTON  
APPLICATION FOR  
USE OF TOWN MEETING FACILITY**

Name/Organization Boston Democratic Social Club Date 2/20/2024

Name of person responsible for facilities Barbara Moore

Title \_\_\_\_\_

Applicant Address \_\_\_\_\_ Colden, NY 14033

Applicant Daytime Phone # 716-912-2100 # Of Attendees: 10

Date(s) Requested\* attached Time 7-8:30pm Type of Event meeting

**I, THE UNDERSIGNED, REQUEST PERMISSION TO USE THE FOLLOWING: (check all that apply)**

Town Hall Community Room w/o Kitchen

Planning Board Room

Court Room

**I agree that all facilities used will be properly cleaned to the best of my ability upon completion of the event and that I will be responsible for any damages caused to any of the facilities or grounds .**

SIGNATURE OF APPLICANT: Barbara Moore <sup>270</sup>

**Upon Completion, please submit to Town Clerk**

\*\*\*\*\*

**APPROVED/DENIED:** 2/27/2024  
(date)

INSPECTION: \_\_\_\_\_  
(date)



## Sandra Quinlan

---

**From:** Barbara Moore <411eci@gmail.com>  
**Sent:** Tuesday, February 20, 2024 2:48 PM  
**To:** Sandra Quinlan  
**Subject:** Reserving Planning Board Room

**Follow Up Flag:** Follow up  
**Flag Status:** Flagged

The Boston Democratic Social Club would like to use the Planning Board Room on the following dates for 2024:

March 19

April 16

May 21

June 18

July 16

August 20

September 17

October 15

November 19

December 17

Thank you,  
Barbara

**TOWN OF BOSTON  
APPLICATION FOR  
USE OF TOWN MEETING FACILITY**

Name/Organization Town of Boston Date 2/9/24

Name of person responsible for facilities Jason Keding

Title Town Supervisor

Applicant Address 8500 Boston State Rd.

Applicant Daytime Phone # 716-941-6518 # Of Attendees: 12-15

Date(s) Requested\* 2/13 & 2/15 Time 6-9pm Type of Event meeting

**I, THE UNDERSIGNED, REQUEST PERMISSION TO USE THE FOLLOWING: (check all that apply)**

Town Hall Community Room w/o Kitchen

Planning Board Room

Court Room

I agree that all facilities used will be properly cleaned to the best of my ability upon completion of the event and that I will be responsible for any damages caused to any of the facilities or grounds .

SIGNATURE OF APPLICANT: 

Upon Completion, please submit to Town Clerk

\*\*\*\*\*

**APPROVED/DENIED:** 2/9/2024  
(date)

INSPECTION: \_\_\_\_\_  
(date)

**TOWN OF BOSTON  
APPLICATION FOR  
USE OF TOWN MEETING FACILITY**

Name/Organization Town of Boston Date 2 / 29 / 2024

Name of person responsible for facilities Jason Keding

Title Supervisor

Applicant Address 8500 Boston State Rd.

Applicant Daytime Phone # 941-6518 # Of Attendees: 20

Date(s) Requested\* 3/18, 4/22, 5/20 Time 7p-9p Type of Event meeting for Comp Plan

I, THE UNDERSIGNED, REQUEST PERMISSION TO USE THE FOLLOWING: (check all that apply)

Town Hall Community Room w/o Kitchen

Planning Board Room

Court Room

I agree that all facilities used will be properly cleaned to the best of my ability upon completion of the event and that I will be responsible for any damages caused to any of the facilities or grounds .

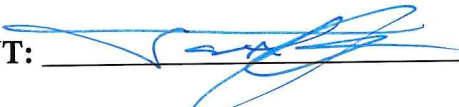
SIGNATURE OF APPLICANT: 

Upon Completion, please submit to Town Clerk

\*\*\*\*\*

APPROVED/DENIED : 2/29/2024  
(date)

INSPECTION: \_\_\_\_\_  
(date)

**TOWN OF BOSTON  
APPLICATION FOR  
USE OF TOWN MEETING FACILITY**

Name/Organization Town of Boston Date 2 / 29 / 2024

Name of person responsible for facilities Jason Keding

Title Supervisor

Applicant Address 8500 Boston State Rd.

Applicant Daytime Phone # 941-10518 # Of Attendees: 50 x

Date(s) Requested\* 4/10/24 Time 10:30p-8:30p Type of Event Public mtg

**I, THE UNDERSIGNED, REQUEST PERMISSION TO USE THE FOLLOWING: (check all that apply)**

- Town Hall Community Room w/o Kitchen — if Girl Scouts cancel this is our first pick
- Planning Board Room
- Court Room

I agree that all facilities used will be properly cleaned to the best of my ability upon completion of the event and that I will be responsible for any damages caused to any of the facilities or grounds .

SIGNATURE OF APPLICANT: 

Upon Completion, please submit to Town Clerk

\*\*\*\*\*

APPROVED / DENIED : 2/29/2024  
(date)

INSPECTION: \_\_\_\_\_  
(date)



## AGREEMENT

THIS AGREEMENT, to be effective as of January 1, 2024, is by and between the Town of Boston, New York (“the Town”), a municipal corporation organized and existing under the laws of the State of New York with offices at 8500 Boston State Road, Boston, New York, and Boston Seniors (the “Contractor”):

WHEREAS, pursuant to General Municipal Law §95-a the Town is authorized to contract with private, nonprofit corporations, associations, institutions, or agencies for the operation and maintenance of programs devoted in whole or in part to the welfare of the aging; and

WHEREAS, the Contractor operates a program devoted to the welfare of the aging in the Town;

WITNESSETH, that the Town and the Contractor, for the consideration hereinafter named, agree as follows:

1. Contractor shall furnish a program open to all senior citizens within the Town of Boston that promotes the welfare of the aging through cultural, artistic, and/or social opportunities (the “Program”). Contractor may establish a minimum age for participation in the Program, but covenants not to discriminate against any Program participant on the basis of age, race, creed, color, national origin, sexual orientation, military status, sex, marital status, disability, or for any other reason.
2. The Town will reimburse contractor or pay directly on behalf of contractor an amount not to exceed **\$15,000** during the period from January 1, 2024 to December 31, 2024 for Program expenses which benefit all participants in attendance at a Program offered by Contractor, such as entertainment, transportation, and material costs.
3. The Town’s funds are to be used to benefit Town residents who participate in Contractor’s Program and any benefit for non-residents should be incidental. The Town’s funds may be used for the purpose of providing awards and recognition to individual participants in Contractor’s programs, but the value or any such award or recognition purchased using the Town’s funds shall not exceed \$20 per individual, and the Town’s funds shall not otherwise be used to purchase gift cards or certificates or for payments, subsidies, grants, or other benefits provided to individual program participants.
4. Contractor shall maintain books and records reflecting its expenditure of Town funds for a period of six years, and shall provide these records for Town inspection upon request.
5. Contractor is an independent contractor, and shall not be considered an employee or agent for the Town.
6. Each party shall indemnify, defend, and hold the other party harmless from all liabilities, costs and expenses (including, without limitation, attorneys’ fees) that such party may suffer, sustain or become subject to as a result of the indemnifying party’s negligence or willful misconduct in performance of its obligations under this Agreement.



7. Contractor is prohibited from assigning or transferring this Agreement without the prior written consent of the Town.
8. Each and every provision of law and clause required by law to be inserted in this Agreement shall be deemed to have been inserted herein. If any such provision is not inserted, through mistake or otherwise, then upon the application of either party, this Agreement shall be physically amended forthwith to make such insertion.
9. No waiver of any breach of any condition of the Agreement shall be binding unless in writing and signed by the party waiving said breach. No such waiver shall in any way affect any other term or condition of this Agreement or constitute a cause or excuse for a repetition of such or any other breach unless the waiver shall include the same.
10. The individuals executing this Agreement personally warrant that they have full authority to execute this Agreement on behalf of the entity for whom they are acting herein.

IN WITNESS WHEREOF, the parties hereto have caused this agreement to be executed effective the day and year first above written.

Town of Boston

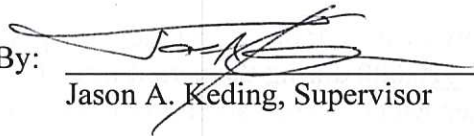
By:   
Jason A. Keding, Supervisor

Boston Seniors

By:   
Bill Davis, President

## AGREEMENT

THIS AGREEMENT, to be effective as of January 1, 2024, is by and between the Town of Boston, New York (“the Town”), a municipal corporation organized and existing under the laws of the State of New York with offices at 8500 Boston State Road, Boston, New York, and Boston Young at Heart (the “Contractor”):

WHEREAS, pursuant to General Municipal Law §95-a the Town is authorized to contract with private, nonprofit corporations, associations, institutions, or agencies for the operation and maintenance of programs devoted in whole or in part to the welfare of the aging; and

WHEREAS, the Contractor operates a program devoted to the welfare of the aging in the Town;

WITNESSETH, that the Town and the Contractor, for the consideration hereinafter named, agree as follows:

1. Contractor shall furnish a program open to all senior citizens within the Town of Boston that promotes the welfare of the aging through cultural, artistic, and/or social opportunities (the “Program”). Contractor may establish a minimum age for participation in the Program, but covenants not to discriminate against any Program participant on the basis of age, race, creed, color, national origin, sexual orientation, military status, sex, marital status, disability, or for any other reason.
2. The Town will reimburse contractor or pay directly on behalf of contractor an amount not to exceed **\$15,000** during the period from January 1, 2024 to December 31, 2024 for Program expenses which benefit all participants in attendance at a Program offered by Contractor, such as entertainment, transportation, and material costs.
3. The Town’s funds are to be used to benefit Town residents who participate in Contractor’s Program and any benefit for non-residents should be incidental. The Town’s funds may be used for the purpose of providing awards and recognition to individual participants in Contractor’s programs, but the value or any such award or recognition purchased using the Town’s funds shall not exceed \$20 per individual, and the Town’s funds shall not otherwise be used to purchase gift cards or certificates or for payments, subsidies, grants, or other benefits provided to individual program participants.
4. Contractor shall maintain books and records reflecting its expenditure of Town funds for a period of six years, and shall provide these records for Town inspection upon request.
5. Contractor is an independent contractor, and shall not be considered an employee or agent for the Town.
6. Each party shall indemnify, defend, and hold the other party harmless from all liabilities, costs and expenses (including, without limitation, attorneys’ fees) that such party may suffer, sustain or become subject to as a result of the indemnifying party’s negligence or willful misconduct in performance of its obligations under this Agreement.

7. Contractor is prohibited from assigning or transferring this Agreement without the prior written consent of the Town.
8. Each and every provision of law and clause required by law to be inserted in this Agreement shall be deemed to have been inserted herein. If any such provision is not inserted, through mistake or otherwise, then upon the application of either party, this Agreement shall be physically amended forthwith to make such insertion.
9. No waiver of any breach of any condition of the Agreement shall be binding unless in writing and signed by the party waiving said breach. No such waiver shall in any way affect any other term or condition of this Agreement or constitute a cause or excuse for a repetition of such or any other breach unless the waiver shall include the same.
10. The individuals executing this Agreement personally warrant that they have full authority to execute this Agreement on behalf of the entity for whom they are acting herein.

IN WITNESS WHEREOF, the parties hereto have caused this agreement to be executed effective the day and year first above written.

Town of Boston

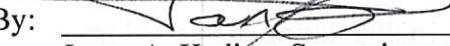
By:   
Jason A. Keding, Supervisor

Boston Young at Heart

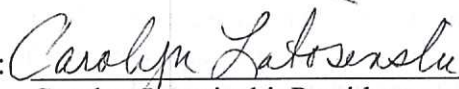
By:   
Carolyn Latosinski, President

## 2023 Energy Use Data

### Town of Boston Covered Municipal Buildings over 1,000 square feet

Property Name	Address	Preoperty Use	Property Gross Floor Area (GFA) - (ft <sup>2</sup> )	Site Energy Use Intensity (EUI) (kBtu/ft <sup>2</sup> )	Weather Normalized Source EUI (kBtu/ft <sup>2</sup> )	Annual GHG Emissions (Metric Tons CO <sub>2</sub> e)	ENERGY STAR Score	Electricity Use - Grid Purchase (kWh)	Natural Gas Use (kBtu)
Town Hall	8500 Boston State Rd.	Office	13,000	69.0	125.5	39.8	38	105,236	538,265
Emergency Squad/Parks	8500 Boston State Rd.	Office	5,100	61.4	91.5	15.4	N/A	16,392	257,069
Boys & Girls Club	8500 Boston State Rd	Other - Recreation	4,500	51.3	81	11.1	N/A	15,456	177,963
Highway Garage	6401 Town Park Ln.	Repair Services	15,200	70.6	99.6	54.7	N/A	30,480	968,886

During 2023, municipal buildings in the Town of Boston over 1,000 square feet used a total of 167,564 kWh of electricity, 1904.1 McF of natural gas, and emitted 121 metric tons of CO<sub>2</sub> equivalent.



Energy Use by Calendar Month (Not Weather Normalized) for Boston Town Hall

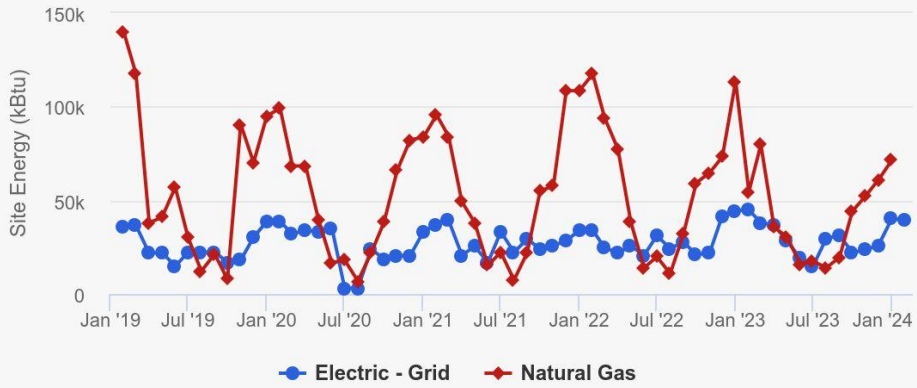

Energy Use by Calendar Month (Not Weather Normalized) for Boston Boys & Girls Club

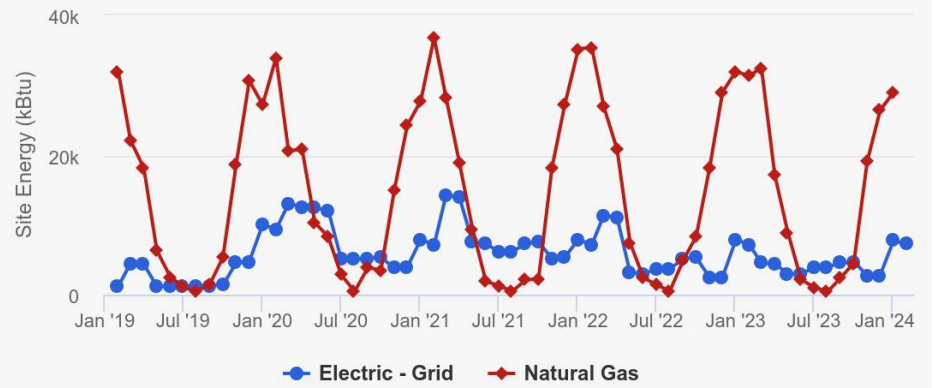

Energy Use by Calendar Month (Not Weather Normalized) for Boston Emergency Squad/Parks

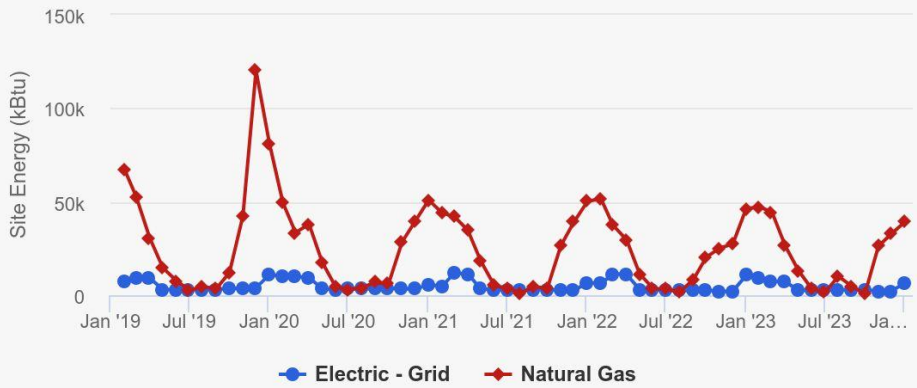

Energy Use by Calendar Month (Not Weather Normalized) for Boston Highway Garage

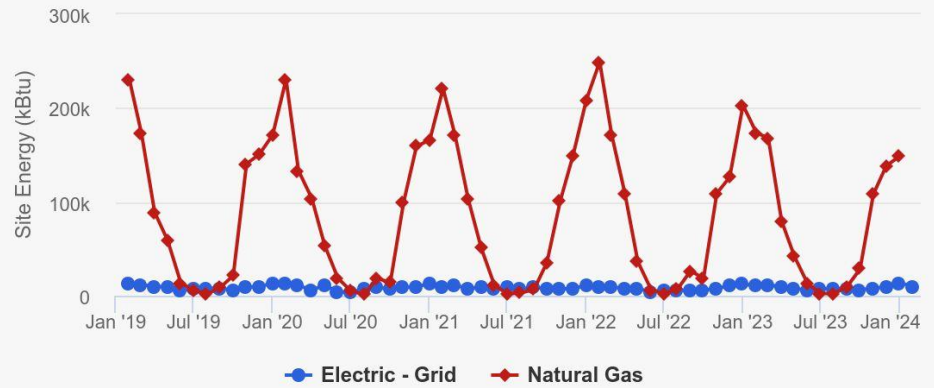



Deborah Catalano

Boston, NY 14025

FEB 29 2024 4:09:19

02/26/2024

Dear Town Board,

This letter is to inform you that I will be resigning my position on the Assessment Board of Review as of 02/26/2024.

Thank you,

*Deborah Catalano*

Deborah Catalano



# County of Erie

**Mark Poloncarz**  
COUNTY EXECUTIVE

## DEPARTMENT OF SENIOR SERVICES

Angela Marinucci  
Commissioner

(716) 858-6046  
FAX: (716) 858-6597

February 28, 2024

Dear Site Managers and Directors:

The Erie County Stay-Fit Dining program, including Frozen meals, will be closed on Monday, April 8<sup>th</sup>, 2024 due to the total solar eclipse event happening that day.

All meal programs will resume as normal on Tuesday, April 9<sup>th</sup>. Please contact your visiting Erie County nutrition staff if you have any further questions or concerns, including scheduling an alternate date for frozen pick up, if applicable.

The Department of Senior Services strongly recommends that community members should begin planning from now to ensure that they have enough food, medication, and any other essentials prior to April 8<sup>th</sup> so that they may stay in place to witness this historic event from the comfort of their home. Closing the nutrition programs is our first step in decreasing the amount older adults traveling on the day of the Eclipse and reduce unnecessary traffic.

An unprecedented number of visitors are expected in Western New York to witness this once-in-a-lifetime event. Many of these visitors will be travelling into our area that morning and most are expected to leave immediately after. Imagine the drive home from a Buffalo Bills game, but 10 times the volume stretching throughout the entire County. State and local officials warn that roads could be in gridlock for most of the day. Overloaded cell towers, a depleted gasoline supply, and temporary grocery shortages are also possible. **Everyone who chooses to travel anywhere on that day should be prepared for significant delay, no matter how short the trip.**

**We are asking for your help in communicating with older adults in your area what to expect on that day and our recommendations for how to properly prepare.** Thank you for your understanding and partnership in helping keep this incredible event enjoyable for everyone!

Best,

Angela J. Marinucci  
Commissioner

**TOWN OF BOSTON – RESOLUTION NO. 2024-21**

**INDEMNIFICATION AND HOLD HARMLESS AGREEMENT  
RELATED TO GATE IN EASEMENT GRANTED TO TOWN**

**WHEREAS**, Paul and Crystal Black are the owners of real property located in the Town of Boston, and more particularly described in a certain deed duly recorded in the office of the Clerk of the County of Erie in Liber of Deeds 11305 at page 5995 (the “Black Property”); and

**WHEREAS**, the Black Property is subject to an easement granted to the Town of Boston and more particularly described in an easement dated July 28, 2005 and duly recorded in the office of the Clerk of the County of Erie in Liber of Deeds 11098 at page 5995 (the “Easement”); and

**WHEREAS**, the Easement allows for ingress and egress by pedestrians and vehicles between the Wohlhueter Road and a Town property where the water tower is located (the “Easement Area”), and includes the non-exclusive right of the Town, its successors, agents, employees, contractors, invitees, and designees to install a driveway and related drainage facilities upon the Easement and to enter upon the Easement at any and all times for purposes of maintenance and repair; and

**WHEREAS**, Erie County Water Authority (the “Authority”) operates and manages the water tower on behalf of the Town pursuant to a Lease Management Agreement entered by and between the Town and the Authority on October 8, 1998, as amended on April 21, 2005, and this includes using the Easement Area; and

**WHEREAS**, the Easement requires that there is open access to the Easement area and specifically states that “the Easement Area shall be kept open and free of obstructions at all times...so as to permit ... use [of] the Easement Area without interference;” and

**WHEREAS**, the Blacks have installed a gate on the Easement area for their security and convenience but in contravention of the terms of the Easement; and

**WHEREAS**, rather than demand the immediate removal of the gate, the Town, Authority, and Blacks now are considering entering into an agreement for the Blacks to indemnify and hold both the Town and the Authority harmless as to any damage and/or injuries which may be caused as result of the installation of said gate, inclusive of all claims, suits, causes of action, judgments or damages sustained by the Town or the Authority or any other person or persons for bodily injury or for injury to or loss of property resulting from, caused by or arising out of the conduct of owners, their agents, servants or invitees;

**NOW, THEREFORE, BE IT**

**RESOLVED**, that the Town Board of the Town of Boston hereby authorizes the Town Supervisor to execute the proposed Indemnification and Hold Harmless agreement between the Town, Erie County Water Authority, and Paul and Crystal Black, relative to a gate erected by the Blacks in contravention of the terms of an easement to the Town.

On April 6, 2024, the question of the adoption of the foregoing Resolution was duly put to a vote on roll call, which resulted as follows:

	<b>Yes</b>	<b>No</b>	<b>Abstain</b>	<b>Absent</b>
Councilmember Cartechine	[   ]	[   ]	[   ]	[   ]
Councilmember Lucachik	[   ]	[   ]	[   ]	[   ]
Councilmember Martin	[   ]	[   ]	[   ]	[   ]
Councilmember Selby	[   ]	[   ]	[   ]	[   ]
Supervisor Keding	[   ]	[   ]	[   ]	[   ]

---

**Sandra L. Quinlan, Town Clerk**



## HOLD HARMLESS AND INDEMNITY AGREEMENT

This Agreement made and entered on this \_\_\_\_ day of March, 2024, by and between Paul Black and Crystal Black, residing at 7737 Wohlhueter Road, Colden, New York (“Black”), the Town of Boston, New York, a municipal corporation with offices at 8500 Boston State Road, Boston, New York (the “Town”), and the Erie County Water Authority, a public benefit corporation, with offices located at 295 Main Street, Room 350, Buffalo, New York (the “Authority”).

**WHEREAS**, Black is the owner of real property located in the Town of Boston, and more particularly described in a certain deed duly recorded in the office of the Clerk of the County of Erie in Liber of Deeds 11305 at page 5995 (the “Black Property”); and

**WHEREAS**, the Black Property is subject to an easement granted to the Town and more particularly described in an easement dated July 28, 2005 and duly recorded in the office of the Clerk of the County of Erie in Liber of Deeds 11098 at page 5995 (the “Easement”); and

**WHEREAS**, the Town of Boston is the owner of real property located in the Town of Boston, and more particularly described in a certain deed duly recorded in the office of the Clerk of the County of Erie in Liber of Deeds 10884 at page 8523 (the “Town Property”); and

**WHEREAS**, a water tower is located on the Town Property and the Authority operates and manages the water tower on behalf of the Town pursuant to a Lease Management Agreement entered by and between the Town and the Authority on October 8, 1998, as amended on April 21, 2005; and

**WHEREAS**, the Easement allows for ingress and egress by pedestrians and vehicles between the Wohlhueter Road and the Town Property (the “Easement Area”), and includes the non-exclusive right of the Town, its successors, agents, employees, contractors, invitees, and designees to install a driveway and related drainage facilities upon the Easement and to enter upon the Easement at any and all times for purposes of maintenance and repair; and

**WHEREAS**, the Easement further requires that there is open access to the Easement area and specifically states that “the Easement Area shall be kept open and free of obstructions at all times...so as to permit ... use [of] the Easement Area without interference;” and

**WHEREAS**, Black has installed a gate on the Easement area in contravention of the terms of the Easement for the security and convenience of Black; and

**WHEREAS**, Black now agrees to indemnify and hold both the Town and the Authority harmless as to any damage and/or injuries which may be caused as result of the installation of said gate, inclusive of all claims, suits, causes of action, judgments or damages sustained by the Town or the Authority or any other person or persons for bodily injury or for injury to or loss of property resulting from, caused by or arising out of the conduct of owners, their agents, servants or invitees.

**NOW, THEREFORE,** in consideration of the mutual promises contained herein and other further consideration, the parties agree as follows:

1. To the fullest extent permitted by law, Black, their heirs, successors, and assigns shall indemnify, defend, and hold harmless the Town and the Authority, their Board of Commissioners, directors, officers, employees, agents, contractors, invitees, designees, servants, and visitors to whom the Town or the Authority are legally responsible, from and against any and all liability, claims, fines, losses, actions, judgments, damages, costs, expenses, fees, including but not limited to attorney's fees, in connection with the Town's and the Authority's use, enjoyment, maintenance, and control of the Easement Area.

2. To the fullest extent permitted by law, Black, their heirs, successors, and assigns shall and hereby indemnify, defend, and hold harmless the Town and the Authority, their Board of Commissioners, directors, officers, employees, agents, contractors, invitees, designees, servants, and visitors to whom the Town of Boston or ECWA are legally responsible, from and against any and all liability, claims, fines, losses, actions, judgments, damages, costs, expenses, fees, including but not limited to attorney's fees, in connection with bodily injury, death, or property damage arising from or out of any occurrence relating to, either directly or indirectly to, any acts or omissions of the Town or the Authority, their Board of Commissioners, directors, officers, employees, agents, contractors, invitees, and designees.

3. Black agrees to pay for all expenses associated with and shall not seek reimbursement from the Town or the Authority for returning the Easement Area to its original condition, which includes but is not limited to any gate or fence repair and/or replacement needed or that will be needed on or for the Easement Area.

4. This Agreement shall be governed by the Law of the State of New York.

5. This Agreement shall not be changed, modified, or altered except in a written instrument signed by all parties.

6. This Agreement shall inure to the benefit of and be enforceable against the parties hereto and their respective successors and assigns.

7. This Agreement constitutes the entire agreement between the parties relating to and within the subject matter and is intended to supersede any prior agreements between the parties with respect to the subject matter herein.

8. Any notice permitted or required to be given by terms of this agreement shall be in writing and shall be deemed to be sufficiently given only if delivered personally or mailed by certified mail, return receipt requested, to the addresses set forth above for the parties, or such other addresses as any party may here after designate by written notice to the other parties given in conformity with this section.

9. This Agreement may be executed in counterparts.

**IN WITNESS WHEREOF**, the parties hereto have caused this Agreement to be executed by the proper party thereunto as of the day and year first above written.

\_\_\_\_\_  
Paul Black

\_\_\_\_\_  
Crystal Black

**TOWN OF BOSTON**

By: \_\_\_\_\_  
Jason Keding, Supervisor

**ERIE COUNTY WATER AUTHORITY**

By: \_\_\_\_\_  
Jerome D. Schad, Chair

Acknowledgements to follow.

STATE OF NEW YORK     )  
COUNTY OF ERIE        ) ss:

On the \_\_\_\_ day of \_\_\_\_\_, 2024, before me, the undersigned, a Notary Public in and for the State, personally appeared PAUL BLACK, personally known to me or proved to me on the basis of satisfactory evidence to be the individual whose name is subscribed to the within instrument and acknowledged to me that he executed the same in his capacity, and that by his signature on the instrument, the individual, or the person upon behalf of which the individual acted, executed the instrument.

---

Notary Public

STATE OF NEW YORK     )  
COUNTY OF ERIE        ) ss:

On the \_\_\_\_ day of \_\_\_\_\_, 2024, before me, the undersigned, a Notary Public in and for the State, personally appeared CRYSTAL BLACK, personally known to me or proved to me on the basis of satisfactory evidence to be the individual whose name is subscribed to the within instrument and acknowledged to me that she executed the same in her capacity, and that by her signature on the instrument, the individual, or the person upon behalf of which the individual acted, executed the instrument.

---

Notary Public

STATE OF NEW YORK     )  
COUNTY OF ERIE        ) ss:

On the \_\_\_\_ day of \_\_\_\_\_, 2024, before me, the undersigned, a Notary Public in and for the State, personally appeared JASON KEDING, to me known, who being by me duly sworn did depose and say that he resides in Boston, New York, that he is the Supervisor of the Town of Boston, described in the above instrument, and he signed his name thereto by authorization of the Town Board of the Town of Boston pursuant to a duly enacted resolution.

---

Notary Public

STATE OF NEW YORK     )  
COUNTY OF ERIE        ) ss:

On the \_\_\_\_ day of \_\_\_\_\_, 2024, before me, the undersigned, a Notary Public in and for the State, personally appeared JEROME D. SCHAD, to me known, who being by me duly sworn did depose and say that he resides in Amherst, New York, that he is the Chairman of the Erie County Water Authority, the public benefit corporation described in the above instrument, and he signed his name thereto by authorization of the Board of Commissioners of the Erie County Water Authority pursuant to a duly enacted resolution.

---

Notary Public

DRAFT



**TOWN OF BOSTON – RESOLUTION NO. 2024-22**

**REFERRING LARGE-SCALE SOLAR PROJECT TO PLANNING BOARD AND CONSERVATION ADVISORY COUNCIL FOR REVIEW AND COMMENT**

**WHEREAS**, the Town of Boston has received applications for zoning variances, a special use permit, and site plan review from NY Boston II, LLC, an entity associated with Delaware River Solar, related to the development of a 3.6-megawatt solar facility at 7832 Feddick Road, the first proposed large-scale solar development in the Town; and

**WHEREAS**, the Town Board has classified the solar project as a SEQR Type I action and declared its intent to serve as lead agency, with no other agency seeking lead agency status; and

**WHEREAS**, the Town has engaged special counsel and Town Engineer CPL to review the project and the SEQR form submitted by the applicant in advance of issuing a declaration regarding the project’s potential impacts on the environment; and

**WHEREAS**, the Town Board expects its engineer and special counsel to have completed their review of the applicant’s submissions by the end of March, and seeks the input, if any, of the Planning Board and Conservation Advisory Committee relative to the reports of the engineer and special counsel;

**NOW THEREFORE BE IT**

**RESOLVED**, that Town Board of the Town of Boston hereby requests that the Planning Board and Conservation Advisory Committee review the reports of the Town Engineer and/or the Town’s special counsel regarding the potential environmental impact of the proposed large-scale solar development at 7832 Feddick Road at their April 2024 meetings, and that any comments or further questions be provided to the Town Board by April 12, so that this matter may be further considered at the Town Board’s April 17 meeting.

On March 6, 2024, the question of the adoption of the foregoing Resolution was duly put to a vote on roll call, which resulted as follows:

	<b>Yes</b>	<b>No</b>	<b>Abstain</b>	<b>Absent</b>
Councilmember Cartechine	[ ]	[ ]	[ ]	[ ]
Councilmember Lucachik	[ ]	[ ]	[ ]	[ ]
Councilmember Martin	[ ]	[ ]	[ ]	[ ]
Councilmember Selby	[ ]	[ ]	[ ]	[ ]
Supervisor Keding	[ ]	[ ]	[ ]	[ ]

---

**Sandra L. Quinlan, Town Clerk**

# Friends of the Boston Library Inc.

RECEIVED  
BOSTON TOWN CLERK

7001 FEB 16 PM 9:44



PO Box 200, Boston, NY 14025  
716.941.3516  
bos@buffalolib.org

8500 Boston State Road  
Boston, NY 14025

February 15, 2024

Dear Town of Boston Board,

On behalf of the Friends of the Boston Library, I wish to request that you consider waiving the facility use fee for the use of the Lions Shelter for the Boston Free Library's Summer Fundraiser planned for Thursday, July 25th.

The Library's 2023 Summer Fundraiser was a success! The Lions Shelter location allows the library to plan a much larger scale community event, and we were so grateful for your contribution in waiving the fee last year. We hope to be able to replicate the success of last year's event.

Thank you for your consideration and for your continued support!

Sincerely,

Lydia Herren, Director



# TOWN OF BOSTON

## APPLICATION FOR USE OF FACILITY

**This Application is subject to Approval by the Town Board and MUST be received at least 1 week prior to Town Board meeting**

**\*\*\*Application, fees, plans, layouts and any additional proof from other agencies must be completed and submitted at time of application. Must be a Boston Resident to request use.\*\*\***

Name/Organization Boston Free Library Date 2 / 15 / 24

Name of person responsible for facilities Lydia Herren  
 Title Director

Applicant Address 9475 Boston State Road

Applicant Daytime Phone # 716-941-3516 # Of Attendees: 250

Date(s) Requested\* 7/25/2024 Time 5-8 pm Type of Event Fundraiser  
 Set Up same day 2:30 - 5:00 pm Take Down same day 8:00 - 9:30 pm

**Sporting Leagues** — Please attach Schedule

**\*\*Certificate of Insurance from your organization must be submitted at least 1 week before your 1st sporting event\*\***

**\*\*\*Please confirm that your dates do not conflict with any Sporting Leagues\*\*\***

Baseball—Josh Haeick	716-649-6170	Football—Nick Jagow	716-725-9680
Southtown Slammers/ Mike Bellagamba	716-225-7936	Soccer—Jessica Blesy	716-809-0121

**I, THE UNDERSIGNED, REQUEST PERMISSION TO USE THE FOLLOWING: (check all that apply)**

- |   |  |
|---|--|
| <input type="checkbox"/> South Boston Park Shelter                                      | Boston Town Park   |
| <input type="checkbox"/> Town Hall Community Room w/ Kitchen<br>And Bathroom Facilities | <input checked="" type="checkbox"/> Lions Shelter<br>✓ And Bathroom Facilities |
| <input type="checkbox"/> North Boston Park Fields                                       | <input type="checkbox"/> Small Shelter   |
|   | <input type="checkbox"/> Town Fields   |

**WILL YOUR EVENT HAVE ANY OF THE FOLLOWING: (Check all that apply)**

- Parade - Who will provide traffic control? \_\_\_\_\_  
 (Submit proof in writing from that agency at time of application)
- Parking (over 50) - Please submit parking Plan: (This must be approved by Park's Superintendent before submittal to Town Clerk with application)
- Rides (Certificate of Insurance from your insurance company must be submitted 1 week before use begins)
- Fireworks (Certificate of Insurance from Firework Vendor must be submitted 1 week before your event)  
 -Who will provide Fire Stand By? \_\_\_\_\_  
 (Submit proof in writing from that agency at time of application)
- Vendors (over 5) - Please submit Layout (This must be approved by Park's Superintendent before submittal to Town Clerk with application)

Alcoholic Beverages:  
(IF SERVING ALCOHOL, CHECK ALL  
THAT APPLY)

Are you serving alcohol?  Yes  No  
Are you having a Private Party?  Yes  No  
Are you having a Public Special Event?  Yes  No

**PLEASE NOTE:** ALL parties must submit a Certificate of Insurance 1 week before your event.  
Public Special Events serving alcohol must also submit a copy of your NYS Liquor License 1 week before your event.

Certificates of Insurance: You must list the Town of Boston as additionally insured and the dates of the event must be on the Certificate of Insurance. Your insurance agent can help you with this. The following is a list of Liability amounts needed:

Private Party (Host Liquor)	\$ 500,000
Public Special Event (Liquor Legal)	\$1,000,000
Ride Vendor	\$1,000,000
Fireworks	\$1,000,000
Sporting Leagues	\$1,000,000

**FEES:** A **\$75 Maintenance Fee** must be included with this application. These funds will be utilized to cover the cost of bathroom supplies, final clean up and administrative costs.

**KEYS:** Keys may be picked up on the business day before the scheduled event and should be returned the first business day immediately following.

**TOWN OF BOSTON PROPERTIES ARE SMOKE FREE**

COMMUNITY EVENTS SIGN: If your organization needs to use the Community Announcement sign near the Emergency Squad Bldg, the "Request to use Coming Events Sign" application must be completed and submitted to the Highway/Parks Dept. This form can be obtained from the Town Clerk's Office or at [www.townofboston.com](http://www.townofboston.com).

Requests may be submitted after September 1st the year before your event.

I agree that all facilities used will be properly cleaned to the best of my ability upon completion of the event and that I will be responsible for any damages caused to any of the facilities or grounds. I will submit to the Town Clerk all Certificates of Insurance and NYS Liquor License if necessary at least 1 week prior to my event. I have contacted the above mentioned sporting leagues and there are no conflicts with dates.

SIGNATURE OF APPLICANT: *Lydia Hemen*

Upon Completion, please submit to Town Clerk

\*\*\*\*\*

FEE REC'D \_\_\_\_\_ APPROVED/DENIED : \_\_\_\_\_  
( date) ( date)

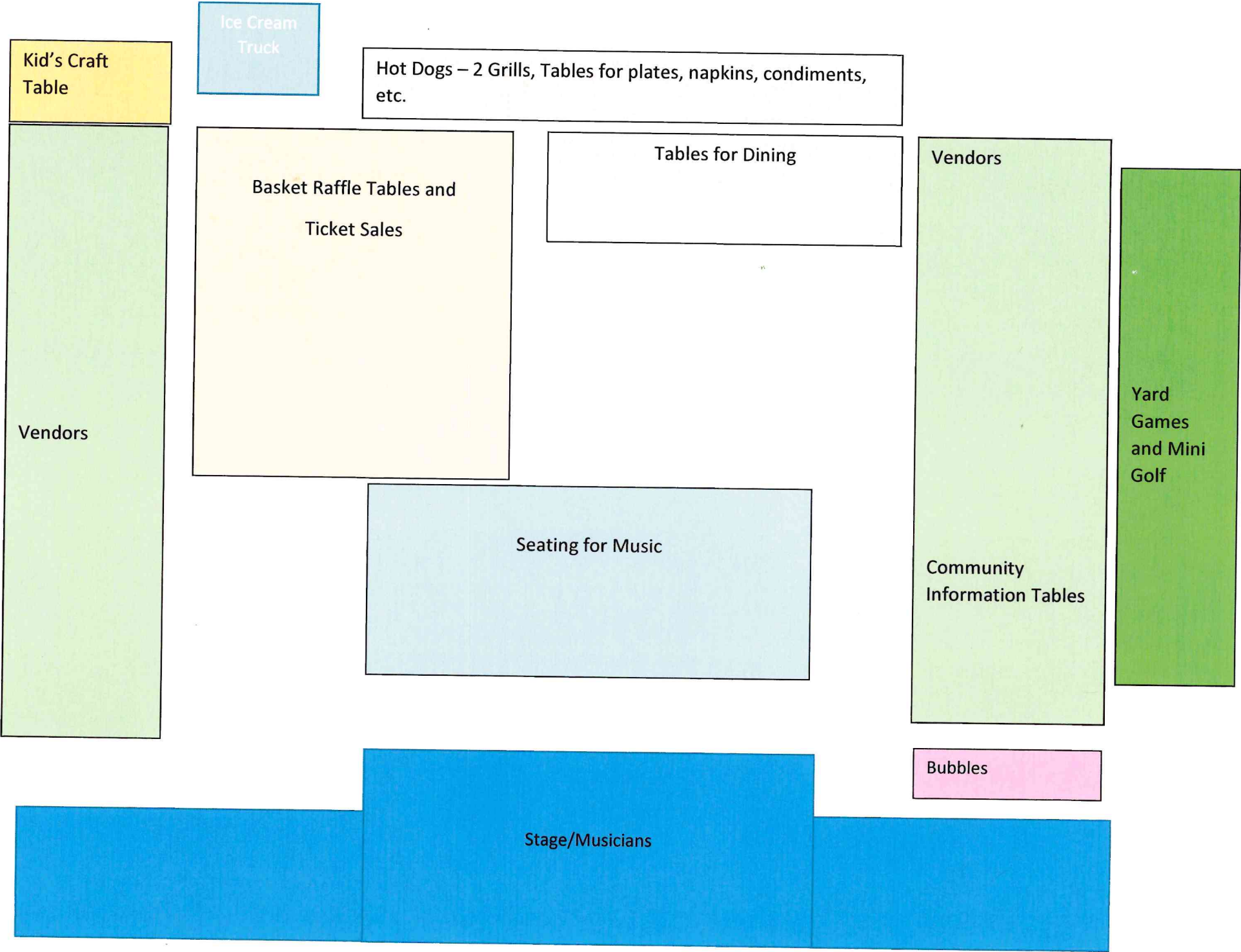



**TOWN OF BOSTON**  
**APPLICATION FOR USE OF FACILITY**

**This Application is subject to Approval by the Town Board  
and MUST be received at least 1 week prior to Town Board meeting**

**\*\*\*Application, fees, plans, layouts and any additional proof from other agencies must be completed and submitted at time of application. Must be a Boston Resident to request use.\*\*\***

Name/Organization ToB Conservation Advisory Council Date 02 / 19 / 24

Name of person responsible for facilities Caitlin Tucker  
Title Member, Conservation Advisory Council

Applicant Address \_\_\_\_\_

Applicant Daytime Phone # \_\_\_\_\_ # Of Attendees: 30

Date(s) Requested\* Saturday, April 6 2024 Time 12pm-2pm Type of Event Education/Outreach  
Set Up 10:30 AM Take Down By 3:00 pm

**Sporting Leagues** — Please attach Schedule

**\*\*Certificate of Insurance from your organization must be submitted at least 1 week before your 1st sporting event\*\***

**\*\*\*Please confirm that your dates do not conflict with any Sporting Leagues\*\*\***

Baseball—Josh Haeick	716-649-6170	Football—Nick Jagow	716-725-9680
Southtown Slammers/ Mike Bellagamba	716-225-7936	Soccer—Jessica Blesy	716-809-0121

**I, THE UNDERSIGNED, REQUEST PERMISSION TO USE THE FOLLOWING: (check all that apply)**

- |  |   |
|--|---|
| <input type="checkbox"/> South Boston Park Shelter   | <input type="checkbox"/> Boston Town Park                         |
| <input checked="" type="checkbox"/> Town Hall Community Room w/ Kitchen<br>And Bathroom Facilities | <input type="checkbox"/> Lions Shelter<br>And Bathroom Facilities |
| <input type="checkbox"/> North Boston Park Fields  | <input type="checkbox"/> Small Shelter                            |
|  | <input type="checkbox"/> Town Fields                              |

**WILL YOUR EVENT HAVE ANY OF THE FOLLOWING: (Check all that apply)**

- Parade - Who will provide traffic control? \_\_\_\_\_  
(Submit proof in writing from that agency at time of application)
- Parking (over 50) - Please submit parking Plan: (This must be approved by Park's Superintendent before submittal to Town Clerk with application)
- Rides (Certificate of Insurance from your insurance company must be submitted 1 week before use begins)
- Fireworks (Certificate of Insurance from Firework Vendor must be submitted 1 week before your event)
- Who will provide Fire Stand By? \_\_\_\_\_  
(Submit proof in writing from that agency at time of application)
- Vendors (over 5) - Please submit Layout (This must be approved by Park's Superintendent before submittal to Town Clerk with application)

Alcoholic Beverages:  
(IF SERVING ALCOHOL, CHECK ALL  
THAT APPLY)

Are you serving alcohol?  
Are you having a Private Party?  
Are you having a Public Special Event?

Yes       No  
 Yes       No  
 Yes       No

**PLEASE NOTE:** ALL parties must submit a Certificate of Insurance 1 week before your event. Public Special Events serving alcohol must also submit a copy of your NYS Liquor License 1 week before your event.

Certificates of Insurance: You must list the Town of Boston as additionally insured and the dates of the event must be on the Certificate of Insurance. Your insurance agent can help you with this. The following is a list of Liability amounts needed:

Private Party (Host Liquor)	\$ 500,000
Public Special Event (Liquor Legal)	\$1,000,000
Ride Vendor	\$1,000,000
Fireworks	\$1,000,000
Sporting Leagues	\$1,000,000

**FEE:** A \$75 Maintenance Fee must be included with this application. These funds will be utilized to cover the cost of bathroom supplies, final clean up and administrative costs.

**KEYS:** Keys may be picked up on the business day before the scheduled event and should be returned the first business day immediately following.

**TOWN OF BOSTON PROPERTIES ARE SMOKE FREE**

COMMUNITY EVENTS SIGN: If your organization needs to use the Community Announcement sign near the Emergency Squad Bldg, the "Request to use Coming Events Sign" application must be completed and submitted to the Highway/Parks Dept. This form can be obtained from the Town Clerk's Office or at [www.townofboston.com](http://www.townofboston.com).

Requests may be submitted after September 1st the year before your event.

I agree that all facilities used will be properly cleaned to the best of my ability upon completion of the event and that I will be responsible for any damages caused to any of the facilities or grounds. I will submit to the Town Clerk all Certificates of Insurance and NYS Liquor License if necessary at least 1 week prior to my event. I have contacted the above mentioned sporting leagues and there are no conflicts with dates.

SIGNATURE OF APPLICANT: Caelyn Tucker

Upon Completion, please submit to Town Clerk

\*\*\*\*\*

FEE REC'D \_\_\_\_\_ APPROVED/DENIED : \_\_\_\_\_  
( date ) (date)

**TOWN OF BOSTON**  
**APPLICATION FOR USE OF FACILITY**

**This Application is subject to Approval by the Town Board  
and MUST be received at least 1 week prior to Town Board meeting**

**\*\*\*Application, fees, plans, layouts and any additional proof from other agencies must be completed and submitted at time of application. Must be a Boston Resident to request use.\*\*\***

Name/Organization Conservation Advisory Council Date 2 / 19 / 24

Name of person responsible for facilities Caitlin Tucker  
Title Member, Conservation Advisory Council

Applicant Address \_\_\_\_\_

Applicant Daytime Phone # \_\_\_\_\_ # Of Attendees: 75

Date(s) Requested\* Saturday May 11 Time 9:30 - 1pm Type of Event Education/Outreach  
Set Up 8:00 AM Take Down 2:00 pm

**Sporting Leagues** — Please attach Schedule

**\*\*Certificate of Insurance from your organization must be submitted at least 1 week before your 1st sporting event\*\***

**\*\*\*Please confirm that your dates do not conflict with any Sporting Leagues\*\*\***

Baseball—Josh Haecik	716-649-6170	Football—Nick Jagow	716-725-9680
Southtown Slammers/ Mike Bellagamba	716-225-7936	Soccer—Jessica Blesy	716-809-0121

**I, THE UNDERSIGNED, REQUEST PERMISSION TO USE THE FOLLOWING: (check all that apply)**

- |  |   |
|--|---|
| <input type="checkbox"/> South Boston Park Shelter   | <input checked="" type="checkbox"/> Boston Town Park              |
| <input checked="" type="checkbox"/> Town Hall Community Room w/ Kitchen<br>And Bathroom Facilities | <input type="checkbox"/> Lions Shelter<br>And Bathroom Facilities |
| <input type="checkbox"/> North Boston Park Fields  | <input type="checkbox"/> Small Shelter                            |
|  | <input type="checkbox"/> Town Fields                              |

**WILL YOUR EVENT HAVE ANY OF THE FOLLOWING: (Check all that apply)**

- |   |   |
|---|---|
| <input type="checkbox"/> Parade               | - Who will provide traffic control? _____<br>(Submit proof in writing from that agency at time of application)                          |
| <input type="checkbox"/> Parking<br>(over 50) | - Please submit parking Plan: _____<br>(This must be approved by Park's Superintendent before submittal to Town Clerk with application) |
| <input type="checkbox"/> Rides                | (Certificate of Insurance from your insurance company must be submitted 1 week before use begins)                                       |
| <input type="checkbox"/> Fireworks            | (Certificate of Insurance from Firework Vendor must be submitted 1 week before your event)  |
|   | -Who will provide Fire Stand By? _____<br>(Submit proof in writing from that agency at time of application)                             |
| <input type="checkbox"/> Vendors<br>(over 5)  | - Please submit Layout _____<br>(This must be approved by Park's Superintendent before submittal to Town Clerk with application)        |

Alcoholic Beverages:  
(IF SERVING ALCOHOL, CHECK ALL  
THAT APPLY)

Are you serving alcohol?  
Are you having a Private Party?  
Are you having a Public Special Event?

Yes     No  
 Yes     No  
 Yes     No

**PLEASE NOTE:** ALL parties must submit a Certificate of Insurance 1 week before your event. Public Special Events serving alcohol must also submit a copy of your NYS Liquor License 1 week before your event.

Certificates of Insurance: You must list the Town of Boston as additionally insured and the dates of the event must be on the Certificate of Insurance. Your insurance agent can help you with this. The following is a list of Liability amounts needed:

Private Party (Host Liquor)	\$ 500,000
Public Special Event (Liquor Legal)	\$1,000,000
Ride Vendor	\$1,000,000
Fireworks	\$1,000,000
Sporting Leagues	\$1,000,000

**FEES:** A **\$75 Maintenance Fee** must be included with this application. These funds will be utilized to cover the cost of bathroom supplies, final clean up and administrative costs.

**KEYS:** Keys may be picked up on the business day before the scheduled event and should be returned the first business day immediately following.

**TOWN OF BOSTON PROPERTIES ARE SMOKE FREE**

COMMUNITY EVENTS SIGN: If your organization needs to use the Community Announcement sign near the Emergency Squad Bldg, the "Request to use Coming Events Sign" application must be completed and submitted to the Highway/Parks Dept. This form can be obtained from the Town Clerk's Office or at [www.townofboston.com](http://www.townofboston.com).

Requests may be submitted after September 1st the year before your event.

I agree that all facilities used will be properly cleaned to the best of my ability upon completion of the event and that I will be responsible for any damages caused to any of the facilities or grounds. I will submit to the Town Clerk all Certificates of Insurance and NYS Liquor License if necessary at least 1 week prior to my event. I have contacted the above mentioned sporting leagues and there are no conflicts with dates.

SIGNATURE OF APPLICANT: Caeflin Tucker

Upon Completion, please submit to Town Clerk

\*\*\*\*\*

FEE REC'D \_\_\_\_\_ APPROVED/DENIED : \_\_\_\_\_  
( date ) ( date )

RECEIVED  
BOSTON TOWN CLERK  
JUN 20 21 11 0:29

**TOWN OF BOSTON**  
**APPLICATION FOR USE OF FACILITY**

**This Application is subject to Approval by the Town Board  
and MUST be received at least 1 week prior to Town Board meeting**

**\*\*\*Application, fees, plans, layouts and any additional proof from other agencies must be completed and submitted at time of application. Must be a Boston Resident to request use.\*\*\***

Name/Organization Trooper Brinkerhoff Foundation Date 2 / 16 / 24

Name of person responsible for facilities Mike Brinkerhoff  
Title President

Applicant Address Orchard Park, NY 14127

Applicant Daytime Phone # \_\_\_\_\_ # Of Attendees: 500

Date(s) Requested\* June 15 Time 7-1:00 Type of Event Race

Set Up Friday June 14 4:00-7:00 Community Room Take Down Saturday June 15 1:00-2:00

**Sporting Leagues** — Please attach Schedule

**\*\*Certificate of Insurance from your organization must be submitted at least 1 week before your 1st sporting event\*\***

**\*\*\*Please confirm that your dates do not conflict with any Sporting Leagues\*\*\***

Baseball—Josh Haeick	716-649-6170	Football—Nick Jagow	716-725-9680
Southtown Slammers/ Mike Bellagamba	716-225-7936	Soccer—Jessica Blesy	716-809-0121

**I, THE UNDERSIGNED, REQUEST PERMISSION TO USE THE FOLLOWING: (check all that apply)**

- |   |  |
|---|--|
| <input type="checkbox"/> South Boston Park Shelter  | <input type="checkbox"/> Boston Town Park                                    |
| <input checked="" type="checkbox"/> Town Hall Community Room <u>                    </u><br><u>                    </u> | <input checked="" type="checkbox"/> Lions Shelter<br>And Bathroom Facilities |
| <input type="checkbox"/> North Boston Park Fields   | <input type="checkbox"/> Small Shelter                                       |
|   | <input type="checkbox"/> Town Fields   |

**WILL YOUR EVENT HAVE ANY OF THE FOLLOWING: (Check all that apply)**

- |  |  |
|--|--|
| <input type="checkbox"/> Parade                          | - Who will provide traffic control? <u>Patchin Fire Co &amp; NYSP</u><br>(Submit proof in writing from that agency at time of application) |
| <input checked="" type="checkbox"/> Parking<br>(over 50) | - Please submit parking Plan: (This must be approved by Park's Superintendent before submittal to Town Clerk with application)             |
| <input type="checkbox"/> Rides                           | (Certificate of Insurance from your insurance company must be submitted 1 week before use begins)  |
| <input type="checkbox"/> Fireworks                       | (Certificate of Insurance from Firework Vendor must be submitted 1 week before your event)   |
|  | -Who will provide Fire Stand By? _____<br>(Submit proof in writing from that agency at time of application)                                |
| <input type="checkbox"/> Vendors<br>(over 5)             | - Please submit Layout (This must be approved by Park's Superintendent before submittal to Town Clerk with application)                    |



Alcoholic Beverages:  
(IF SERVING ALCOHOL, CHECK ALL  
THAT APPLY)

Are you serving alcohol?  
Are you having a Private Party?  
Are you having a Public Special Event?

Yes     No  
 Yes     No  
 Yes     No

**PLEASE NOTE:** ALL parties must submit a Certificate of Insurance 1 week before your event.  
Public Special Events serving alcohol must also submit a copy of your NYS Liquor License 1 week before your event.

Certificates of Insurance: You must list the Town of Boston as additionally insured and the dates of the event must be on the Certificate of Insurance. Your insurance agent can help you with this. The following is a list of Liability amounts needed:

Private Party (Host Liquor)            \$ 500,000  
Public Special Event (Liquor Legal)    \$1,000,000  
Ride Vendor                                \$1,000,000  
Fireworks                                  \$1,000,000  
Sporting Leagues                         \$1,000,000

**FEES:** A **\$75 Maintenance Fee** must be included with this application. These funds will be utilized to cover the cost of bathroom supplies, final clean up and administrative costs.

**KEYS:** Keys may be picked up on the business day before the scheduled event and should be returned the first business day immediately following.

**TOWN OF BOSTON PROPERTIES ARE SMOKE FREE**

COMMUNITY EVENTS SIGN: If your organization needs to use the Community Announcement sign near the Emergency Squad Bldg, the "Request to use Coming Events Sign" application must be completed and submitted to the Highway/Parks Dept. This form can be obtained from the Town Clerk's Office or at [www.townofboston.com](http://www.townofboston.com).

Requests may be submitted after September 1st the year before your event.

I agree that all facilities used will be properly cleaned to the best of my ability upon completion of the event and that I will be responsible for any damages caused to any of the facilities or grounds. I will submit to the Town Clerk all Certificates of Insurance and NYS Liquor License if necessary at least 1 week prior to my event. I have contacted the above mentioned sporting leagues and there are no conflicts with dates.

SIGNATURE OF APPLICANT: M. Billoff

Upon Completion, please submit to Town Clerk

\*\*\*\*\*

FEE REC'D 2/21/2024 APPROVED/DENIED : \_\_\_\_\_  
(date) (date)  
ch #614 \$75.00

Highway  
Dept.

Parking



Town  
Shelter

Parking

Boys &  
Girls  
Club

LAV

LAV

Grounds

E  
M  
S

**TOWN OF BOSTON** RECEIVED  
FACILITY CLERK  
**APPLICATION FOR USE OF SPORTING FACILITY**

**This Application is subject to Approval by the Town Board and MUST be received at least 1 week prior to Town Board meeting.**

Organization Name: Boston Youth Soccer League

Organization Representative Name: Dillon Patterson

Representative's Title: Vice President

Applicant Address: \_\_\_\_\_

Applicant Daytime Phone: \_\_\_\_\_ Estimated # Of Attendees: 150

\*\*\*Please coordinate field use with other Sporting Leagues. Contact information can be found below.\*\*\*

League Name	Representative	Phone Number
Southtowns Slammers	Mike Bellagamba	716-225-7936
Boston Youth Soccer League	Jessica Blesy	716-809-0121
Boston Patriots Football & Cheerleading	Bill Frascella	716-548-8111
Hamburg Baseball	Josh Haeick	716-649-6170

**SCHEDULE OF FEES**

Sporting Field Reservations	\$50 <sup>00</sup> per 3-hour block of time
-----------------------------	---

**\*No refunds will be issued in the event of cancellations/inclement weather.\***

**In order to ensure the Town of Boston residents have an opportunity to enjoy the Town's recreational facilities, Youth Sporting Leagues sponsored by not-for-profit organizations based in the Town of Boston which offer recreational opportunities to Town youth may make seasonal reservations for a fee of \$250.** Boston Patriots Football shall also pay the actual cost of any Department of Health permit fee associated with its operation of the snack shack.

Fee includes a facilities cleaning fee. The Town reserves the right to reject future use of facility applications or to cancel events scheduled by organizations that fail to pay required fees or provide satisfactory proof of comprehensive general liability insurance in the amount of at least \$1,000,000 naming the Town as additional insured at least one week prior to the date of the event. The Town reserves the right to revoke permission for use of facilities for applicants who refuse to cooperate with Town employees, cause excessive damage, or whose players or spectators create unsafe conditions.

Requests may be submitted after September 1st the year before your event. The Town Parks Department should be notified of any changes to scheduled events. Best efforts will be made, but chalking/painting/lining of fields is not guaranteed.

**TOWN OF BOSTON**  
**APPLICATION FOR USE OF SPORTING FACILITY**

**AGREEMENT**

By my signature below, I hereby represent that I have full authority to submit this Application and if the Application is accepted to enter into this Agreement on behalf of the organization named above.

I agree that all facilities used will be properly cleaned to the best of my ability upon completion of the event and that I will be responsible for any damages caused to any of the facilities or grounds. I will submit to the Town Clerk all Certificates of Insurance at least 1 week prior to my event. I have contacted the above mentioned sporting leagues and there are no conflicts with dates.

By my signature below, the organization named above (or individual, if an individual) agrees to indemnify, defend, and hold harmless, to the greatest extent allowed by law, the Town and its officers, agents, employees, servants, and representatives from and against any and all damages, injuries, death, dismemberment, lawsuits, liabilities, claims, costs, and expenses, including reasonable attorney fees, arising in whole or part from: (i) the use of the Town's facilities by Applicant in connection with this Application and Agreement, or anyone claiming by, through or under Applicant; (ii) acts of third parties in connection with Applicant's use of the Town's facilities; or (iii) the breach of any of Applicant's representations, warranties, covenants or agreements, hereunder, including Damages arising from the combined fault of Applicant and Town, but excluding any damages arising solely from the negligence or willful misconduct of the Town.

SIGNATURE OF APPLICANT: *Dillo Patterson*

Upon Completion, please submit to Town Clerk

\*\*\*\*\*

FEE RECEIVED: 2/20/2024 ch# 220  
(DATE) \$ 250.00

APPLICATION AND AGREEMENT ACCEPTED AND APPROVED BY TOWN BOARD VOTE ON: \_\_\_\_\_  
(DATE)

APPLICATION AND AGREEMENT REJECTED BY TOWN BOARD ON: \_\_\_\_\_  
(DATE)

NOTES:  
- Proof of current insurance will be needed one week prior to 7-1-24.

# TOWN OF BOSTON

## APPLICATION FOR USE OF SPORTING FACILITY SCHEDULING

Date	Time	Field/Park (check box)	Diamond/Field Request
7-1-2024 to 10-5-2024	5:30pm	<input checked="" type="checkbox"/> Town Hall Park <input checked="" type="checkbox"/> North Boston Park <input type="checkbox"/> South Boston Park	<input type="checkbox"/> Diamond 1 <input type="checkbox"/> Diamond 2 <input type="checkbox"/> Diamond 3 <input type="checkbox"/> Diamond 4  <input checked="" type="checkbox"/> Soccer Fields <input type="checkbox"/> Football Practice Fields <input type="checkbox"/> Football Game Field
		<input type="checkbox"/> Town Hall Park <input type="checkbox"/> North Boston Park <input type="checkbox"/> South Boston Park	<input type="checkbox"/> Diamond 1 <input type="checkbox"/> Diamond 2 <input type="checkbox"/> Diamond 3 <input type="checkbox"/> Diamond 4  <input type="checkbox"/> Soccer Fields <input type="checkbox"/> Football Practice Fields <input type="checkbox"/> Football Game Field
		<input type="checkbox"/> Town Hall Park <input type="checkbox"/> North Boston Park <input type="checkbox"/> South Boston Park	<input type="checkbox"/> Diamond 1 <input type="checkbox"/> Diamond 2 <input type="checkbox"/> Diamond 3 <input type="checkbox"/> Diamond 4  <input type="checkbox"/> Soccer Fields <input type="checkbox"/> Football Practice Fields <input type="checkbox"/> Football Game Field
		<input type="checkbox"/> Town Hall Park <input type="checkbox"/> North Boston Park <input type="checkbox"/> South Boston Park	<input type="checkbox"/> Diamond 1 <input type="checkbox"/> Diamond 2 <input type="checkbox"/> Diamond 3 <input type="checkbox"/> Diamond 4  <input type="checkbox"/> Soccer Fields <input type="checkbox"/> Football Practice Fields <input type="checkbox"/> Football Game Field
		<input type="checkbox"/> Town Hall Park <input type="checkbox"/> North Boston Park <input type="checkbox"/> South Boston Park	<input type="checkbox"/> Diamond 1 <input type="checkbox"/> Diamond 2 <input type="checkbox"/> Diamond 3 <input type="checkbox"/> Diamond 4  <input type="checkbox"/> Soccer Fields <input type="checkbox"/> Football Practice Fields <input type="checkbox"/> Football Game Field
		<input type="checkbox"/> Town Hall Park <input type="checkbox"/> North Boston Park <input type="checkbox"/> South Boston Park	<input type="checkbox"/> Diamond 1 <input type="checkbox"/> Diamond 2 <input type="checkbox"/> Diamond 3 <input type="checkbox"/> Diamond 4  <input type="checkbox"/> Soccer Fields <input type="checkbox"/> Football Practice Fields <input type="checkbox"/> Football Game Field
		<input type="checkbox"/> Town Hall Park <input type="checkbox"/> North Boston Park <input type="checkbox"/> South Boston Park	<input type="checkbox"/> Diamond 1 <input type="checkbox"/> Diamond 2 <input type="checkbox"/> Diamond 3 <input type="checkbox"/> Diamond 4  <input type="checkbox"/> Soccer Fields <input type="checkbox"/> Football Practice Fields <input type="checkbox"/> Football Game Field
		<input type="checkbox"/> Town Hall Park <input type="checkbox"/> North Boston Park <input type="checkbox"/> South Boston Park	<input type="checkbox"/> Diamond 1 <input type="checkbox"/> Diamond 2 <input type="checkbox"/> Diamond 3 <input type="checkbox"/> Diamond 4  <input type="checkbox"/> Soccer Fields <input type="checkbox"/> Football Practice Fields <input type="checkbox"/> Football Game Field
		<input type="checkbox"/> Town Hall Park <input type="checkbox"/> North Boston Park <input type="checkbox"/> South Boston Park	<input type="checkbox"/> Diamond 1 <input type="checkbox"/> Diamond 2 <input type="checkbox"/> Diamond 3 <input type="checkbox"/> Diamond 4  <input type="checkbox"/> Soccer Fields <input type="checkbox"/> Football Practice Fields <input type="checkbox"/> Football Game Field
		<input type="checkbox"/> Town Hall Park <input type="checkbox"/> North Boston Park <input type="checkbox"/> South Boston Park	<input type="checkbox"/> Diamond 1 <input type="checkbox"/> Diamond 2 <input type="checkbox"/> Diamond 3 <input type="checkbox"/> Diamond 4  <input type="checkbox"/> Soccer Fields <input type="checkbox"/> Football Practice Fields <input type="checkbox"/> Football Game Field
		<input type="checkbox"/> Town Hall Park <input type="checkbox"/> North Boston Park <input type="checkbox"/> South Boston Park	<input type="checkbox"/> Diamond 1 <input type="checkbox"/> Diamond 2 <input type="checkbox"/> Diamond 3 <input type="checkbox"/> Diamond 4  <input type="checkbox"/> Soccer Fields <input type="checkbox"/> Football Practice Fields <input type="checkbox"/> Football Game Field



**TOWN OF BOSTON – RESOLUTION NO. 2024-18**

**REPAIR, COATING, AND STRIPING OF SPORTS COURTS**

**WHEREAS**, the hard-surface sports courts at the Town of Boston’s Town Park are in a state of disrepair, with cracked, uneven surfaces that no longer are properly striped; and

**WHEREAS**, the Town has obtained a proposal from Super Seal Sealcoating LLC dated October 27, 2023 to power-wash, repair cracks and low spots, coat the surface with colored material, and line stripe the Town’s hard-surface courts at Boston Town Park, which consist of one basketball court, two tennis courts, and two pickleball courts, for a total cost of \$83,200; and

**WHEREAS**, the Town can procure Super Seal’s services by “piggybacking” pursuant to General Municipal Law § 103(16) off Equalis Group public sector purchasing cooperative’s Master Agreement Contract No. COG-2138B with SportMaster for Sports Construction Services, as Super Seal Sealcoating is an authorized dealer pursuant to the SportMaster Master Agreement; and

**WHEREAS**, the Town Board wishes to restore the Town’s hard-surface sports courts to allow residents to fully benefit from these amenities;

**NOW THEREFORE BE IT**

**RESOLVED**, that Town Board of the Town of Boston hereby authorizes the procurement from Super Seal Sealcoating LLC of repairs, coating, and striping of the sports courts at Boston Town Park, as described in that firm’s October 27, 2023 proposal and for a total cost not to exceed \$83,200.

On March 6, 2024, the question of the adoption of the foregoing Resolution was duly put to a vote on roll call, which resulted as follows:

	<b>Yes</b>	<b>No</b>	<b>Abstain</b>	<b>Absent</b>
Councilmember Cartechine	[ ]	[ ]	[ ]	[ ]
Councilmember Lucachik	[ ]	[ ]	[ ]	[ ]
Councilmember Martin	[ ]	[ ]	[ ]	[ ]
Councilmember Selby	[ ]	[ ]	[ ]	[ ]
Supervisor Keding	[ ]	[ ]	[ ]	[ ]

---

**Sandra L. Quinlan, Town Clerk**

Super Seal Sealcoating LLC

PO Box 925  
Penfield, NY 14526



**Proposal**

Phone: 585-248-5770

Fax: 585-248-5951

Name / Address		Date	10/27/2023	Proposal #	7857
Town of Boston 8500 Boston State Road Boston NY 14025		Job Name:	2024 Court Repairs		
		Phone/Fax:			

We Submit Specifications & Estimates for:	Total
<p>Proposal to power-wash, provide long-term crack repair to existing cracks, color-coat courts and line stripe courts. Per discussion, this proposal includes line striping for one basketball court, two tennis courts, and two pickleball courts. An option that to have permanent net posts installed for the two pickleball courts is listed in this proposal, but it is not included in total price of this project.</p> <ol style="list-style-type: none"> <li>1. Proposal includes washing entire court, surface preparation is important for adhesion of coating. Clean playing surface using CYCLONE TR5500 and the CYCLONE CY210 unit for pressure washing. This unit produces hot water and is equipped with a rotating high pressure washing unit capable of producing 4,000 PSI while controlling waste water. Property owners are responsible for a water source for power washer.</li> <li>2. Fill Bird Baths, will reduce puddling but will not eliminate bird baths completely.</li> <li>3. Install RITE WAY CRACK REPAIR SYSTEM UP TO _1091_LF. RITEWAY CRACK REPAIR SYSTEM prevents the cracks from reflecting through only where it is installed. It does not prevent cracking from occurring in other areas of the court, or if existing cracks get longer beyond repair area. RITE WAY CRACK SYSTEM is designed to bridge the existing crack while staying permanently adhered to the court. This prevents the repair from humping. The fabric system is flexible and designed to expand &amp; contract. Depending on the movement, a surface hair line cracks may occur, this is normal and is not a structural defect.</li> <li>4. Apply one (1) coat acrylic resurfacer with 60 mesh sand to entire area</li> <li>5. Apply two (2) coats color with 80 mesh sand to entire area.</li> <li>6. Stripe court with 2' white lines in accordance with USTA. Price includes striping for 2 tennis, 1 basketball, and two pickleball courts.</li> <li>7. Thoroughly clean work area.</li> <li>8. All work done by hand.</li> <li>9. Colors to chosen by owners.</li> </ol> <p>**** Optional installation of two (2) sets of pickleball sleeves, and center strap anchors is additional \$6,000.00 not included in proposal price</p>	83,200.00

Please Sign & Return if Job is Accepted.

<b>Subtotal:</b>	
<b>Sales Tax: (8.0%)</b>	
<b>Total:</b>	

Super Seal Signature

Super Seal Sealcoating LLC  
 PO Box 925  
 Penfield, NY 14526



**Proposal**

Phone: 585-248-5770

Fax: 585-248-5951

Name / Address		Date	10/27/2023	Proposal #	7857
Town of Boston 8500 Boston State Road Boston NY 14025		Job Name:	2024 Court Repairs		
		Phone/Fax:			

We Submit Specifications & Estimates for:	Total
<p>Please Note: This proposals through the Equalis Group COOP and SportMaster Sports Surfaces publicly procured contract vehicle. It will require the Town to become a member of the Equalis Group. It is a 5 minute application to qualify for the COOP Purchasing Program. Super Seal will provide you additional information on the COOP.</p>	

Please Sign & Return if Job is Accepted.

There shall be 1 year guarante on material & workmanship, except as applied to cracks. The guarantee shall be limited to the replacement of material & application of same. The RITE WY CRACK REPAIR SYSTEM could have hair line cracks on outer edge of system. No warranties applied with system

Customer  
 Signature \_\_\_\_\_

<b>Subtotal:</b>	\$83,200.00
<b>Sales Tax: (8.0%)</b>	\$0.00
<b>Total:</b>	\$83,200.00

Super Seal Signature \_\_\_\_\_





# SUPER SEAL

PO BOX 925 | PENFIELD, NY 14526



## Partial List of Sport Surfacing Completed Recently 10/12/22

Addison Central School	Elmira College	Naples CSD	Town of Henrietta
Alexander CSD	Fredonia College	Nazareth College	Town of Mendon
Allendale Columbia Sch	Frewsburg Central CSD	Newfane Central CSD	Town of Ogden
Albion Central School	Gates Chili CSD	Niagara Falls CSD	Town of Owasco
Attica Central School	Greece Central Schools	Palmyra Macedon CSD	Town of Penfield
Aquinas Institute	Harley School	Pavilion Central CSD	Town of Perinton
Avon Central School	Hilton CSD	Phelps Clifton Springs	Town of Perry
Beaver Hollow Center	Hobart College	Penfield Central School	Town of Riga
Binghamton University	Homer Central School	Penfield Country Club	Town of Victor
Bristol Harbour Village	Honeoye Central CSD	Penn Yan CSD	Town of Williamson
Brockport Central CSD	Honeoye Falls-Lima CSD	Perinton Parks Fellows Rd	Victor Central School
City of Canandaigua	Houghton College	Pittsford Parks Thornell Rd	Village of Brockport
City of Fredonia	Irondequoit Ctry Club	Pittsford Mendon School	Village of Caledonia
City of Elmira	Jamesville Dewitt CSD	Roberts Wesleyan	Village Clifton Springs
City of Oneida	JCC of Rochester	Royalton Hartland CSD	Village of Fairhaven
City of Olean	Keshequa Ctl School	Rush Henrietta CSD	Village of LeRoy
City of Rochester	Kendall Central CSD	St. John Fisher College	Village of Manchester
Colgate University	Ken-Ton Schools	Southern Cayuga CSD	Village of Mendon
Cortland SUNY	Keuka College	SUNY Genesee	Village of Perry
County of Monroe	Locust Hill Ctry Club	Tennis Clb of Rochester	Village of Shortsville
Ctry Clb of Rochester	Lyons CSD	Town of Brighton	Village of Silver Creek
Cuba Rushford CSD	Marcellus Central CSD	Town of Chili	Wayne Central School
Dundee Central School	Marion CSD	Town of Cuba	Webster Central School
Dunkirk Central CSD	McQuade High Sch	Town of E. Bloomfield	West Irondequoit School
East Bloomfield CSD	Mid-Town Athletic Club	Town of Farmington	Wilson Central School
	Mid Vale Country Club	Town of Gates	Williamsville CSD
	Mendon Ponds Tennis	Town of Greece	York Central School

## 585-248-5770

[WWW.SUPERSEALCO.COM](http://WWW.SUPERSEALCO.COM)







# Super Seal Sealcoating

P.O.Box 925 ~ Penfield, NY 14526 ~ Phone: (585) 248-5770  
Fax: (585) 248-5951 ~ [supersealco.com](http://supersealco.com) ~ [info@supersealco.com](mailto:info@supersealco.com)



*Greg Duffy, Owner &  
Avid Tennis Player*

## Satisfied Customers:

City of Canandaigua	Mendon Ponds Tennis
City of Rochester	Monroe Country Club
Colgate University	Penfield Central School
Cortland SUNY	Pittsford Mendon School
Country Club of Rochester	Roberts Wesleyan
Fredonia College	St. John Fisher College
Keuka College	Tennis Club of Rochester
McQuaid High School	Transit Valley Country Club
Midtown Athletic Club	

## Court Building & Repair

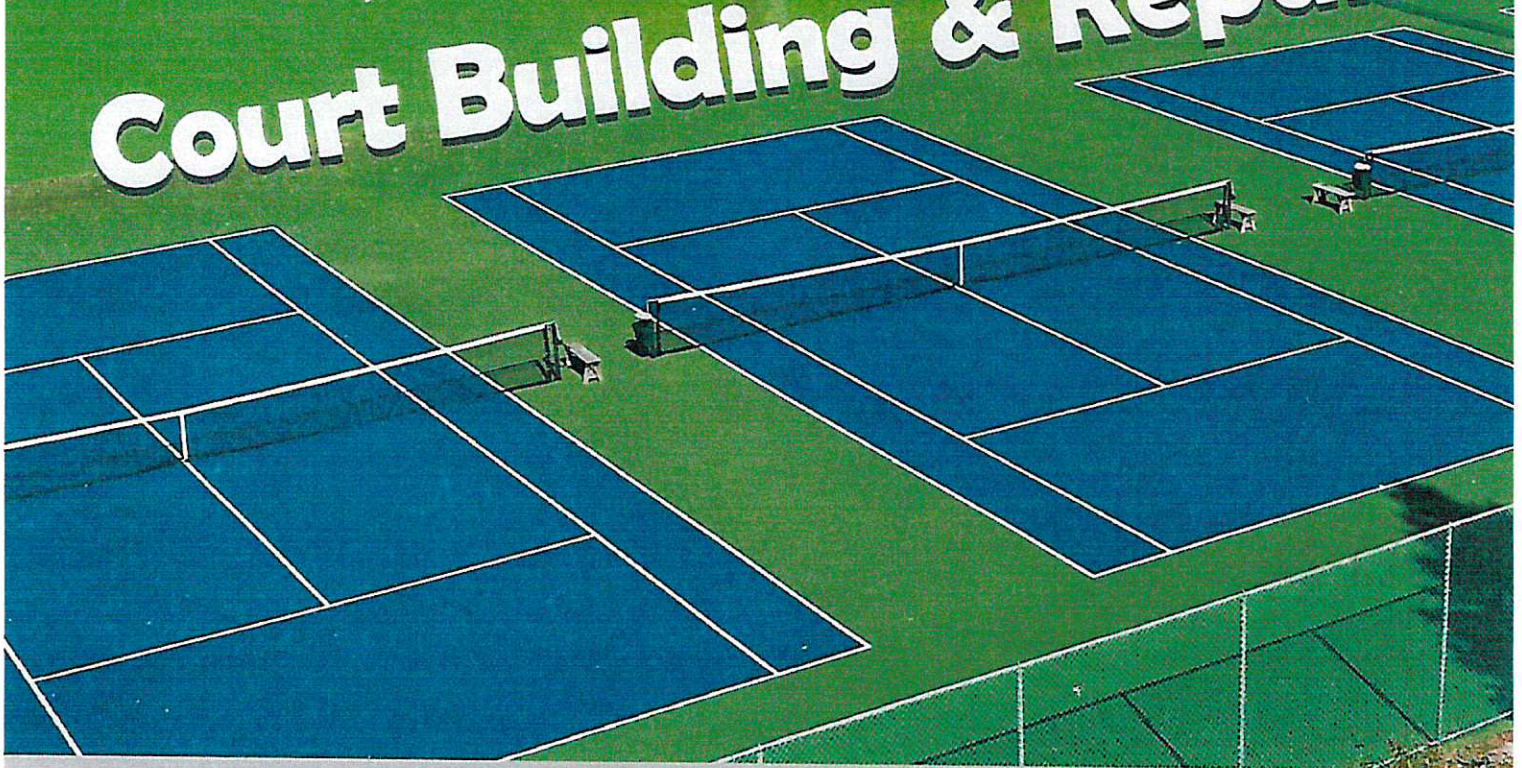

Serving **BUFFALO ~ ROCHESTER ~ SYRACUSE ~ SOUTHERN TIER** since 1986



# Created by Public Sector Organizations for Public Sector Organizations



## Who is Equalis Group?

Equalis Group is a Member-Driven, Supplier-Centric organization that embodies the power of partnership. Equalis Group operates with the guiding principle that when the objectives of buyers and sellers are aligned, sustainable value is created, transcending that of the typical short-term transactional relationship. With this differentiated approach, Equalis Group is not just a cooperative purchasing organization; we are a family.

We leverage Equalis Group members' combined buying power to command better pricing and favorable contract

terms from suppliers. We develop and administer a diverse portfolio of cooperative purchasing programs that cover a wide range of products and services and provide our members with a legal and compliant exemption to the bid/request for proposals (RFP) process.

Each program in our rapidly growing portfolio provides our members with contracting compliance and the ability to configure the solution that best meets their individual needs while achieving the lowest Total Cost of Ownership.

## Time Saved through Equalis Group = More Resources for You to Invest

How many hours and over how many weeks or months does your team invest in a typical solicitation process? How many solicitations does your organization publish each year? How much time and effort can your organization save by leveraging Equalis Group's already-procured portfolio of programs? In what ways can you re-invest that saved time and energy to fulfill your organization's purpose?

### Your Solicitation Process Today



### Your Implementation Process with Equalis Group



## Become a Member of Equalis Group

If you are not already a member, you can join Equalis Group in just minutes and immediately access our portfolio of cooperative purchasing programs. Simply visit [www.equalisgroup.org/member-registration](http://www.equalisgroup.org/member-registration) to get started. There are no dues, fees, or obligations.



## Remain in Compliance with Equalis Group

The Public Sector procurement process is riddled with nuances and regulatory considerations established to safeguard how taxpayer dollars are spent. It is often overwhelming and confusing as purchasers navigate strict guidelines and a combination of local, state, and federal statutory requirements, but it doesn't have to be.

There are three compliant avenues for Public Sector entities to spend taxpayer dollars: 1) conducting stand-alone bids/RFPs/RFOs; 2) purchasing through State Term contracts; and, 3) buying through the types of competitively solicited cooperative agreements Equalis Group offers.

We leverage our extensive Public Sector procurement acumen and decades of experience to ensure our members remain compliant when utilizing our publicly procured cooperative agreements to save time and money.

Equalis Group partners with Lead Agencies, Region 10 Educational Service Center (**Region 10 ESC**) in Texas and The Cooperative Council of Governments (**CCOG**) in Ohio, to conduct rigorous and transparent competitive public sector procurement processes for critical products and services. Winning suppliers, distributors, and manufacturers are selected based on both qualitative criteria and pricing. We then establish compliant already-procured Master Agreements with these winning vendors that are available to public agencies nationwide.

## Equalis Group's Compliant Solicitation Process

### Step 1



#### Prepare Solicitation

Lead Agency identifies member needs

### Step 2



#### Publish Solicitation

Lead Agency publicly advertises & proactively distributes solicitation

### Step 3



#### Open Proposals

Vendors submit proposal responses

### Step 4



#### Evaluate & Award

Lead Agency evaluates responses using transparent criteria & issues contract awards

### Step 5



#### Establish Master Agreement

Lead Agency negotiates final contract & posts on [www.EqualisGroup.org](http://www.EqualisGroup.org)



In short, Equalis Group collaborates with our Lead Agencies to deliver compliant, publicly procured cooperative agreements that Public Sector entities across the country can utilize to: *i)* quickly acquire the products and services they need; *ii)* receive better pricing through the collective buying power of Equalis Group Members; and, *iii)* save time through Equalis Group's legal and compliant alternative to conducting their own resource-consuming solicitation process.





## SportMaster & Equalis Group Publicly Procured Master Agreement Contract #COG-2138B

The Cooperative Council of Governments (**CCOG**), an Equalis Group Lead Agency, issued RFP #COG-2138 for Sports Construction Services on 10/7/2022 and subsequently entered into Contract #COG-2138B with SportMaster as the lowest responsive and responsible bidder. Super Seal Sealcoating is an authorized dealer of the SportMaster Master Agreement.

### Contract Information

**Effective Date:** 1/1/2023  
**Renewable Through:** 12/31/2032

Additional information regarding the procurement process and contract award can be found on the [SportMaster Page](#) at the Equalis Group website, including the SportMaster products and services available through the Master Agreement, RFP and scoring documents, the Master Agreement between CCOG and SportMaster, and pricing/discount model.

### Entities Eligible to Purchase from SportMaster through the Master Agreement

This contract vehicle is immediately available to existing Equalis Group Members.

Not a Member yet? Any public sector entity in the country can join Equalis Group and begin utilizing any Equalis Group competitively solicited master agreement by completing the [membership registration form](#). New Members receive a fully executed copy of their completed membership form via email immediately and will receive their Equalis Group membership number within one-to-two days. There are no dues, fees, or obligations and completing the form takes less than five minutes.

### Help with Membership, Procurement Questions & Navigating Our Contract Portfolio

Equalis Group's dedicated Member Engagement Team exists to support our Members. The team is readily accessible and is prepared to answer questions about membership, public sector purchasing compliance, Equalis Group's procurement and contracting processes, and our portfolio of more than 100 already-procured contract vehicles. Current and prospective Members can find their Member Engagement Team point person and direct contact information [here](#).

View all Equalis Group contracts and download a sortable Excel file with key information about each contract in our ever-expanding portfolio [here](#).

### About Equalis

Equalis Group is a Public Sector purchasing cooperative. We deliver compliant, publicly procured cooperative agreements that Public Sector entities across the country can utilize to: *i*) quickly acquire the products and services they need; *ii*) receive better pricing through the collective buying power of Equalis Group Members; and, *iii*) save time through Equalis Group's legal and compliant alternative to conducting their own resource-consuming solicitation process.

Equalis Group partners with two primary Lead Agencies, Region 10 Education Service Center (**Region 10**) in Texas and The Cooperative Council of Governments (**CCOG**) in Ohio, to conduct rigorous and transparent competitive public sector procurement processes for critical products and services. Winning suppliers, distributors, and manufacturers are selected based on both qualitative criteria and pricing. We then establish compliant already-procured Master Agreements with the winning vendors.



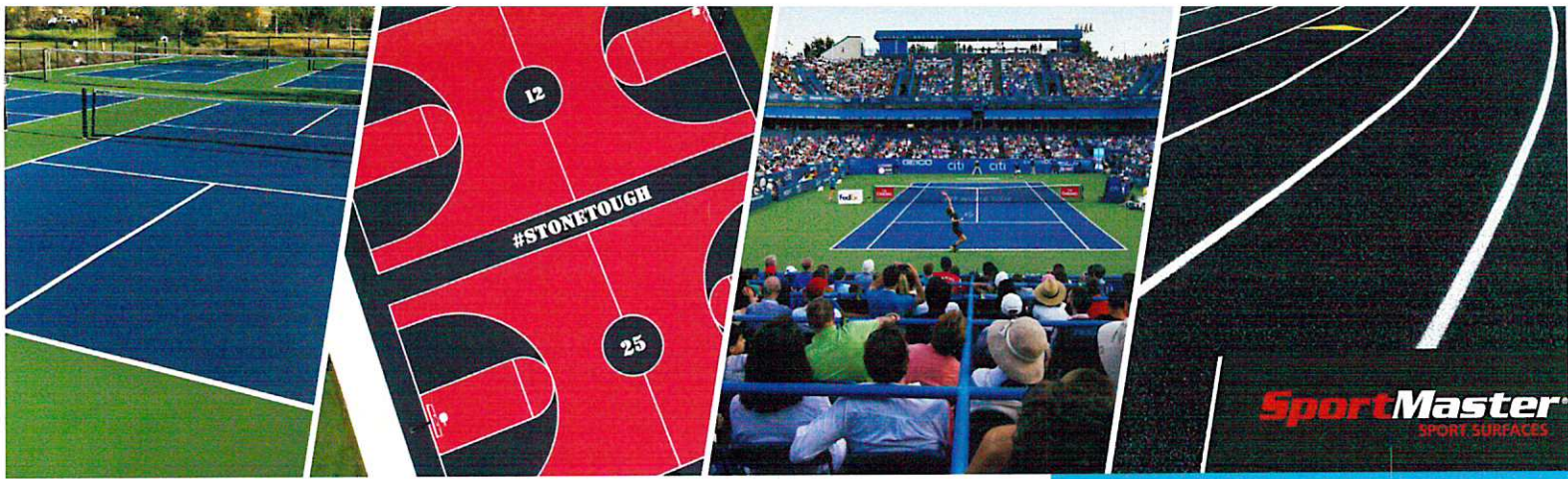

**SportMaster**  
SPORT SURFACES

**e**equalis  
GROUP

## Super Seal Sealcoating & SportMaster & Equalis Group *Publicly Procured Contract Vehicle*

### SportMaster - Super Seal Sealcoating Contract Highlights

- SportMaster is a leading manufacturer of acrylic sport surfaces for tennis, pickleball, basketball, roller hockey, and running tracks.
- Our installers can perform sport surface repairs and surfacing throughout the US.
- There are nearly 100 colors to choose from in our Sport Surfacing Systems, as well as custom logos, windscreen, and other accessories.
- SportMaster is the official surface of USA Pickleball & the United States Professional Tennis Association.
- All 5 ITF (International Tennis Federation) surface paces are available for tennis court surfaces that play slow, medium-slow, medium, medium-fast, or fast.
- With SportMaster representatives nationwide, we can create a free project scope and install all our surfacing systems at the discounted co-op rate.

### Who is Super Seal Sealcoating?

Super Seal is the largest locally independent owned company in N.Y. state that provides coloring of tennis, basketball, pickleball & inline parks. We also have a sealcoating division that can do hot crack filling, sealcoating & striping of parking lots.

### Who is SportMaster?

SportMaster Sport Surfaces is a leading brand of acrylic sport surfacing products, made in the USA. SportMaster is stocked and available through the SealMaster franchise system, with over 115 locations nationwide & 50 plus years in business.

Save Time... we've done the procurement work so you don't have to.

Save Money... your dollar goes further with the collective buying power of Equalis Group.

Stay Legal... our competitive procurement process delivers statutory compliance in every state.

Contract #: COG-2138B

Lead Agency: CCOG

Effective Date: 01.01.2023

Renewable Through: 12.31.2032

Contact Super Seal Sealcoating:

Name: Greg Duffy

Email: [info@supersealco.com](mailto:info@supersealco.com)

Phone: 585-248-5770

## GET STARTED

Learn more about how we can help you achieve your procurement goals while Saving Time, Saving Money & Staying Legal. Email [Engage@EqualisGroup.org](mailto:Engage@EqualisGroup.org) or visit [EqualisGroup.org/Map](http://EqualisGroup.org/Map) to connect with your dedicated Member Engagement Resource today.





## Membership FAQ

**Save Time. Save Money. Stay Legal. That's our commitment to our members.**

### Why Become A Member Of Equalis Group?

Your organization receives immediate access to our [expanding portfolio](#) of compliant, already-procured contract vehicles. These contracts are designed to achieve the lowest Total Cost of Ownership for our members, delivering the best possible overall value. Our contracts feature enhanced contract terms and conditions and aggressive pricing not typically available to individual entities purchasing independently. There is strength in numbers when it comes to buying products and services.

### How Does Equalis Group Work?

Equalis Group collaborates with our Lead Agencies to deliver compliant, publicly procured cooperative agreements that Public Sector entities across the country can utilize to: *i)* quickly acquire the products and services they need directly from our awarded suppliers; *ii)* receive better pricing through the collective buying power of Equalis Group Members; and, *iii)* save time through Equalis Group's legal and compliant alternative to conducting their own resource-consuming solicitation process.

### What Types Of Entities Are Eligible To Join?

Equalis Group membership is available to federal, state, and local government agencies; public and private educational institutions, including K-12 schools, colleges, and universities; non-profit organizations; and private sector companies. Typically, any individual within an organization who is authorized to sign documents on behalf of the organization can complete the membership form without any formal board action, although approval requirements do vary from state to state.

### What's The Catch?

There is no catch. There is no cost to join Equalis Group, and there are no membership dues or obligations of any kind. Joining Equalis Group is like getting a library card – membership simply ensures your organization has access to our contract portfolio. You decide which contracts to utilize and when.

### How Do I Join?

Joining Equalis Group online takes less than five minutes. Simply visit our [Join Page](#) and follow the instructions provided.

If you would rather send us a hard copy of the Membership Agreement, download the Agreement from our [Join Page](#) and email the signed PDF to [Membership@EqualisGroup.org](mailto:Membership@EqualisGroup.org).

### What Happens After Joining?

Immediately after completing the [membership registration form](#) you will receive an email confirmation letting you know that your membership is being processed. Within one to two business days, Equalis Group will email your welcome kit, which includes your membership number. To begin purchasing, simply provide your membership number to an Equalis Group awarded supplier and you will receive the improved pricing and other benefits of our competitively solicited contracts.

### Who Do I Contact For Questions Or To Begin Utilizing Equalis Group Contracts?

If you have any questions about the membership process, would like to learn more about any of our already-procured contracts, or want to start purchasing through one or more of our publicly procured agreements, visit [www.EqualisGroup.org/Map](http://www.EqualisGroup.org/Map) to connect with your dedicated Member Engagement Resource today or send an email to [Engage@EqualisGroup.org](mailto:Engage@EqualisGroup.org).





Member ID	Equalis Contact	Email Address	Account Name	Entity Type	Address	City	State	Zip	Account Phone	Join Date
EG-1AR55AL	Kirk McGonigle	kmcgonigle@equalisgroup.org	Albany College of Pharmacy and Health Sciences	Education - Colleges & Universities	106 New Scotland Ave	Albany	NY	12208		
EG-52RH3AL	Kirk McGonigle	kmcgonigle@equalisgroup.org	Alfred State College	Education - Colleges & Universities	10 Upper College Dr.	Alfred	NY	14802	(800) 425-3733	5/13/2021
EG-0LYP4AL	Kirk McGonigle	kmcgonigle@equalisgroup.org	Alfred University	Education - Colleges & Universities	1 Saxon Drive	Alfred	NY	14802	(518) 436-4781	
EG-1JTE8AN	Kirk McGonigle	kmcgonigle@equalisgroup.org	Andover Central School District	Education - Primary/Secondary/PreK-12	31 Elm	Andover	NY	14806	(607) 478-8491	9/16/2022
EG-2HC16AU	Kirk McGonigle	kmcgonigle@equalisgroup.org	Auburn Enlarged City School District	Education - Primary/Secondary/PreK-12	78 Thornton Ave.	Auburn	NY	13021	3152558811	10/9/2020
EG-0030146	Kirk McGonigle	kmcgonigle@equalisgroup.org	Bedford Stuyvesant Collegiate Charter School	Education - Primary/Secondary/PreK-12	800 Gates Avenue	Brooklyn	NY	11221	718-669-7460	6/29/2022
EG-9JUF8BE	Kirk McGonigle	kmcgonigle@equalisgroup.org	Belfast Central School District	Education - Primary/Secondary/PreK-12	1 King Street	Belfast	NY	14711	(585) 365-9940	6/13/2022
EG-40JP5BI	Kirk McGonigle	kmcgonigle@equalisgroup.org	Binghamton University	Education - Colleges & Universities	4400 Vestal Pkwy	Binghamton	NY	13902		
EG-1JUB8BO	Kirk McGonigle	kmcgonigle@equalisgroup.org	Bolivar-Richburg Central School District	Education - Primary/Secondary/PreK-12	School Street	Bolivar	NY	14715	(585) 928-2937	8/10/2022
EG-0030145	Kirk McGonigle	kmcgonigle@equalisgroup.org	Brooklyn East Collegiate Charter School	Education - Primary/Secondary/PreK-12	832 Marcy Avenue	Brooklyn	NY	11216	718-250-5760	6/29/2022
EG-1CWL2BR	Kirk McGonigle	kmcgonigle@equalisgroup.org	Broome Community College	Education - Colleges & Universities	907 Front Street	Binghamton	NY	13905		
EG-0030147	Kirk McGonigle	kmcgonigle@equalisgroup.org	Brownsville Collegiate Charter School	Education - Primary/Secondary/PreK-12	364 Sackman Street	Brooklyn	NY	11212	718-636-0370	6/29/2022
EG-88MD5BU	Kirk McGonigle	kmcgonigle@equalisgroup.org	Buffalo State College	Education - Colleges & Universities	1300 Elmwood Avenue	Buffalo	NY	14222		
EG-8JW9BCL	Kirk McGonigle	kmcgonigle@equalisgroup.org	Clarkstown Central School District	Education - Primary/Secondary/PreK-12	62 Old Middletown Road	New City	NY	10956	(845) 639-6300	8/18/2022
EG-5COD4CO	Kirk McGonigle	kmcgonigle@equalisgroup.org	Columbia Greene Community College	Education - Colleges & Universities	4400 New York 23	Hudson	NY	12534		
EG-35A38CO	Kirk McGonigle	kmcgonigle@equalisgroup.org	Congregation Beth David	Non-Profit Organization	22 West Maple Avenue	Monsey	NY	10952	(845) 356-5089	12/17/2020
EG-0028216	Kirk McGonigle	kmcgonigle@equalisgroup.org	County of Chemung, NY	Government - County	203 Lake Street	Elmira	NY	14901	(607) 737-1297	9/13/2022
EG-7EEB2DU	Kirk McGonigle	kmcgonigle@equalisgroup.org	Dutchess Community College	Education - Colleges & Universities	53 Pendell Road	Poughkeepsie	NY	12601		
EG-5JXC3EA	Kirk McGonigle	kmcgonigle@equalisgroup.org	EAST RAMAPO CENTRAL SCHOOL DISTRICT (SPRING VALL	Education - Primary/Secondary/PreK-12	105 S MADISON AVE	SPRING VALLEY	NY	10977	(845) 577-6000	6/8/2021
EG-5JXG3EA	Kirk McGonigle	kmcgonigle@equalisgroup.org	East Syracuse Minoa Central School District	Education - Primary/Secondary/PreK-12	407 Fremont Road	East Syracuse	NY	13057	315-434-3000	12/21/2021
EG-6WNM4ED	Kirk McGonigle	kmcgonigle@equalisgroup.org	Educational and Institutional Cooperative Purchasing	Association	2 Jericho Plaza Suit 309	Jericho	NY	11753-1671	(800) 283-2634	7/26/2019
EG-5TOL6EM	Kirk McGonigle	kmcgonigle@equalisgroup.org	Empire State College	Education - Colleges & Universities	Two Union Avenue	Saratoga Springs	NY	12866	(800) 847-3000	
EG-0030665	Kirk McGonigle	kmcgonigle@equalisgroup.org	Erie 1 Board of Cooperative Educational Services	Education - Primary/Secondary/PreK-12	355 Harlem Road	Buffalo	NY	14224	(716) 821-7000	8/25/2022
EG-12WH5ER	Kirk McGonigle	kmcgonigle@equalisgroup.org	Erie Community College	Education - Colleges & Universities	6205 Main St.	Williamsville	NY	14221	(716) 851-1002	
EG-0030148	Kirk McGonigle	kmcgonigle@equalisgroup.org	Excellence Boys Charter School Elementary Academy	Education - Primary/Secondary/PreK-12	225 Patchen Avenue	Brooklyn	NY	11233	718-638-1830	6/29/2022
EG-0030149	Kirk McGonigle	kmcgonigle@equalisgroup.org	Excellence Boys Charter School Middle Academy	Education - Primary/Secondary/PreK-12	225 Patchen Avenue	Brooklyn	NY	11233	718-638-1830	6/29/2022
EG-0030150	Kirk McGonigle	kmcgonigle@equalisgroup.org	Excellence Girls Charter School Elementary Academy	Education - Primary/Secondary/PreK-12	794 Monroe Street	Brooklyn	NY	11221	718-638-1875	6/29/2022
EG-0030151	Kirk McGonigle	kmcgonigle@equalisgroup.org	Excellence Girls Charter School Middle Academy	Education - Primary/Secondary/PreK-12	1600 Park Place	Brooklyn	NY	11233	347-390-0555	6/29/2022
EG-4SWK4GE	Kirk McGonigle	kmcgonigle@equalisgroup.org	Genesee The State University of New York	Education - Colleges & Universities	1 College Circle	Genesee	NY	14454	(585) 245-5000	
EG-4JZU2GR	Kirk McGonigle	kmcgonigle@equalisgroup.org	Greece Central School District	Education - Primary/Secondary/PreK-12	750 Maiden Lane	Rochester	NY	14615	(585) 966-2000	
EG-1JZ2HGR	Kirk McGonigle	kmcgonigle@equalisgroup.org	Greenwood Lake Union Free School District	Education - Primary/Secondary/PreK-12	1247 Lakes Road	Monroe	NY	10950	845-782-8678	6/22/2022
EG-5JAM2HI	Kirk McGonigle	kmcgonigle@equalisgroup.org	Hampton Bays Union Free School District	Education - Primary/Secondary/PreK-12	86 Argonne Road East	Hampton Bays	NY	11946	(631) 723-2100	8/12/2022
EG-0026322	Kirk McGonigle	kmcgonigle@equalisgroup.org	Highland Central School District	Education - Primary/Secondary/PreK-12	320 PANCAKE HOLLOW RD	Highland	NY	12528	845-691-1008	5/18/2021
EG-71HW7HU	Kirk McGonigle	kmcgonigle@equalisgroup.org	Highland Fire District	Government - City	25 Milton Avenue	Highland	NY	12528	845-691-2152	11/8/2021
EG-1JAU2IS	Kirk McGonigle	kmcgonigle@equalisgroup.org	Hudson Valley Community College	Education - Colleges & Universities	80 Vandenberg Ave	Troy	NY	12180	(518) 629-4822	
EG-0028224	Kirk McGonigle	kmcgonigle@equalisgroup.org	Ithaca College	Education - Colleges & Universities	99 Radcliffe Road	Island Park	NY	11558		5/5/2022
EG-9JB12JA	Kirk McGonigle	kmcgonigle@equalisgroup.org	Jamestown City School District	Education - Primary/Secondary/PreK-12	953 Danby Rd	Ithaca	NY	14850		11/4/2021
EG-4CWN9JA	Kirk McGonigle	kmcgonigle@equalisgroup.org	Jamestown Community College	Education - Primary/Secondary/PreK-12	197 Martin Road	Jamestown	NY	14701	716-483-4350	8/4/2022
EG-2JBL2KE	Kirk McGonigle	kmcgonigle@equalisgroup.org	Kenmore - Town of Tonawanda Union Free School District	Education - Primary/Secondary/PreK-12	525 Falconer St	Jamestown	NY	14701	(716) 338-1000	
EG-0030152	Kirk McGonigle	kmcgonigle@equalisgroup.org	Kings Collegiate Charter School	Education - Primary/Secondary/PreK-12	1500 Colvin Boulevard	Buffalo	NY	14223	716-874-8400	6/8/2022
EG-0030153	Kirk McGonigle	kmcgonigle@equalisgroup.org	Kings Elementary School	Education - Primary/Secondary/PreK-12	1084 Lenox Road	Brooklyn	NY	11212	718-342-6047	6/29/2022
EG-5JBY2KI	Kirk McGonigle	kmcgonigle@equalisgroup.org	Lancaster Central School District	Education - Primary/Secondary/PreK-12	905 Winthrop St	Brooklyn	NY	11203	347-390-0460	6/29/2022
EG-0020971	Kirk McGonigle	kmcgonigle@equalisgroup.org	Kirvas Joel Village Union Free School District	Education - Primary/Secondary/PreK-12	48 Bakertown Road, Suite 401	Monroe	NY	10950	(845) 782-2300	8/17/2022
EG-0030155	Kirk McGonigle	kmcgonigle@equalisgroup.org	Lancaster Central School District	Education - Primary/Secondary/PreK-12	177 Central Avenue	Lancaster	NY	14086	716-686-3200	6/3/2022
EG-0030156	Kirk McGonigle	kmcgonigle@equalisgroup.org	Leadership Prep Bedford Stuyvesant Elementary Academy	Education - Primary/Secondary/PreK-12	141 Macon Street	Brooklyn	NY	11216	718-636-0360	6/29/2022
EG-0030158	Kirk McGonigle	kmcgonigle@equalisgroup.org	Leadership Prep Bedford Stuyvesant Middle Academy	Education - Primary/Secondary/PreK-12	141 Macon Street	Brooklyn	NY	11216	718-636-0360	6/29/2022
EG-0030159	Kirk McGonigle	kmcgonigle@equalisgroup.org	Leadership Prep Brownsville Elementary Academy	Education - Primary/Secondary/PreK-12	985 Rockaway Ave	Brooklyn	NY	11212	718-669-7461	6/29/2022
EG-0030160	Kirk McGonigle	kmcgonigle@equalisgroup.org	Leadership Prep Brownsville Middle Academy	Education - Primary/Secondary/PreK-12	213 Osborn Street	Brooklyn	NY	11212	347-390-0540	6/29/2022
EG-0030161	Kirk McGonigle	kmcgonigle@equalisgroup.org	Leadership Prep Canarsie Elementary Academy	Education - Primary/Secondary/PreK-12	1001 E. 100 Street	Brooklyn	NY	11236	347-390-0570	6/29/2022
EG-0030162	Kirk McGonigle	kmcgonigle@equalisgroup.org	Leadership Prep Canarsie Middle Academy	Education - Primary/Secondary/PreK-12	1070 E. 104 Street	Brooklyn	NY	11236	347-390-0560	6/29/2022
EG-0030163	Kirk McGonigle	kmcgonigle@equalisgroup.org	Leadership Prep Ocean Hill Elementary Academy	Education - Primary/Secondary/PreK-12	51 Christopher Ave	Brooklyn	NY	11212	718-250-5767	6/29/2022
EG-0020994	Kirk McGonigle	kmcgonigle@equalisgroup.org	Leadership Prep Ocean Hill Middle Academy	Education - Primary/Secondary/PreK-12	51 Christopher Ave	Brooklyn	NY	11212	347-390-0550	6/29/2022
EG-2JCV2LY	Kirk McGonigle	kmcgonigle@equalisgroup.org	Liverpool Central School District	Education - Primary/Secondary/PreK-12	195 Blackberry Road	Liverpool	NY	13099	(315) 622-7900	1/5/2022
EG-9JCU2MA	Kirk McGonigle	kmcgonigle@equalisgroup.org	Lvons School District	Education - Primary/Secondary/PreK-12	10 Clyde Road	Lyons	NY	14489	(315) 946-2200	4/19/2022
EG-1ECF2MO	Kirk McGonigle	kmcgonigle@equalisgroup.org	Massapeque Union Free School District	Education - Primary/Secondary/PreK-12	4925 Merrick Road	Massapequa	NY	11759	516-308-5000	3/31/2022
EG-32UB5MO	Kirk McGonigle	kmcgonigle@equalisgroup.org	Mohawk Valley Community College	Education - Colleges & Universities	1101 Sherman Drive	Utica	NY	13501		
EG-3PYK4MO	Kirk McGonigle	kmcgonigle@equalisgroup.org	Monroe Community College	Education - Colleges & Universities	1000 E Henrietta Rd	Rochester	NY	14623	(585) 292-2000	
EG-2TLN9NA	Kirk McGonigle	kmcgonigle@equalisgroup.org	Morrisville State College	Education - Colleges & Universities	80 Eaton St.	Morrisville	NY	13408	(315) 684-6046	
EG-0028878	Kirk McGonigle	kmcgonigle@equalisgroup.org	Nassau Community College	Education - Colleges & Universities	1 Education Drive	Garden City	NY	11530	516-572-7300	5/4/2021
EG-0028238	Kirk McGonigle	kmcgonigle@equalisgroup.org	Nassau County Board of Elections	Government - County	240 Old Country Road	Mineola	NY	11501	516-571-2416	11/15/2021
EG-0029721	Kirk McGonigle	kmcgonigle@equalisgroup.org	Nazareth College	Education - Colleges & Universities	4245 East Ave	Rochester	NY	14618		11/4/2021
EG-0029722	Kirk McGonigle	kmcgonigle@equalisgroup.org	New Visions Charter High School for Advanced Math and Science	Education - Primary/Secondary/PreK-12	3000 Avenue X	Brooklyn	NY	11235	(718) 934-9240	4/15/2022





Member ID	Equalis Contact	Email Address	Account Name	Entity Type	Address	City	State	Zip	Account Phone	Join Date
EG-0029215	Kirk McGonigle	kmcgonigle@equalisgroup.org	New Visions Charter High School for Advanced Math and Science	Education - Primary/Secondary/PreK-12	156-10 Baisley Boulevard	Queens	NY	11434		
EG-0029244	Kirk McGonigle	kmcgonigle@equalisgroup.org	New Visions for Public Schools	Education - Primary/Secondary/PreK-12	205 East 42nd Street	New York	NY	10017	212-645-5110	1/20/2022
EG-5HX61NE	Kirk McGonigle	kmcgonigle@equalisgroup.org	Newburgh Enlarged City School District	Education - Primary/Secondary/PreK-12	124 Grand Street	Newburgh	NY	12550	845-563-3481	2/7/2022
EG-6BS25NI	Kirk McGonigle	kmcgonigle@equalisgroup.org	Niagara County Community College	Education - Colleges & Universities	3111 Saunders Settlement Road	Sanborn	NY	14132		6/10/2021
EG-9JEB3NI	Kirk McGonigle	kmcgonigle@equalisgroup.org	Niagara Falls City School District	Education - Primary/Secondary/PreK-12	630 66th Street	Niagara Falls	NY	14304	716-286-4211	
EG-90KE1NO	Kirk McGonigle	kmcgonigle@equalisgroup.org	North Country Community College	Education - Colleges & Universities	23 Santaroni Ave	Saranac Lake	NY	12983		6/1/2022
EG-0029915	Kirk McGonigle	kmcgonigle@equalisgroup.org	North East Joint Fire District	Special District	35 South Avenue	Webster	NY	14580	(585) 872-9526	5/16/2022
EG-9JEQ3NO	Kirk McGonigle	kmcgonigle@equalisgroup.org	North Rockland Central School District	Education - Primary/Secondary/PreK-12	65 Chapel Street	West Haverstraw	NY	10923	845-942-3028	6/23/2021
EG-0030165	Kirk McGonigle	kmcgonigle@equalisgroup.org	Ocean Hill Collegiate Charter School	Education - Primary/Secondary/PreK-12	1137 Herkimer St	Brooklyn	NY	11233	718-250-5765	6/29/2022
EG-0030166	Kirk McGonigle	kmcgonigle@equalisgroup.org	Ocean Hill Elementary School	Education - Primary/Secondary/PreK-12	791 Empire Boulevard	Brooklyn	NY	11213	347-390-3190	6/29/2022
EG-3J517PA	Kirk McGonigle	kmcgonigle@equalisgroup.org	Palenville Fire District	Other	717 New York 32A	Palenville	NY	12463	518-678-3311	6/17/2021
EG-0029050	Kirk McGonigle	kmcgonigle@equalisgroup.org	Rochester Institute Of Technology	Education - Colleges & Universities	335 John Street, Bld 99	Rochester	NY	14623		1/6/2022
EG-0028239	Kirk McGonigle	kmcgonigle@equalisgroup.org	Rochester Institute Of Technology	Education - Colleges & Universities	1 Lomb Memorial Dr	Rochester	NY	14623		11/4/2021
EG-0030169	Kirk McGonigle	kmcgonigle@equalisgroup.org	Rochester Prep Elementary School	Education - Primary/Secondary/PreK-12	899 Jay Street	Rochester	NY	14611	585-235-0008	6/29/2022
EG-0030173	Kirk McGonigle	kmcgonigle@equalisgroup.org	Rochester Prep Elementary School 3	Education - Primary/Secondary/PreK-12	85 St Jacob Street	Rochester	NY	14621	585-368-5110	6/29/2022
EG-0030170	Kirk McGonigle	kmcgonigle@equalisgroup.org	Rochester Prep High School	Education - Primary/Secondary/PreK-12	14 Mark St.	Rochester	NY	14605	585-368-5111	6/29/2022
EG-0030168	Kirk McGonigle	kmcgonigle@equalisgroup.org	Rochester Prep Middle School Brooks Campus	Education - Primary/Secondary/PreK-12	630 Brooks Avenue	Rochester	NY	14619	585-436-8629	6/29/2022
EG-0030174	Kirk McGonigle	kmcgonigle@equalisgroup.org	Rochester Prep Middle School Campus 3	Education - Primary/Secondary/PreK-12	85 St Jacob Street	Rochester	NY	14621	585-498-4455	6/29/2022
EG-0030172	Kirk McGonigle	kmcgonigle@equalisgroup.org	Rochester Prep West Campus Elementary School	Education - Primary/Secondary/PreK-12	305 Andrews St	Rochester	NY	14604	585-368-5090	6/29/2022
EG-0030171	Kirk McGonigle	kmcgonigle@equalisgroup.org	Rochester Prep West Campus Middle School	Education - Primary/Secondary/PreK-12	432 Chili Ave	Rochester	NY	14611	585-368-5090	6/29/2022
EG-0029947	Kirk McGonigle	kmcgonigle@equalisgroup.org	Rockland BOCES	Education - Primary/Secondary/PreK-12	65 Parrott Road	West Nyack	NY	10994	(845) 627-4746	5/19/2022
EG-4TKG4SC	Kirk McGonigle	kmcgonigle@equalisgroup.org	Schenectady County Community College	Education - Colleges & Universities	78 Washington Ave	Schenectady	NY	12305	(518) 381-1200	
EG-8JIF2SI	Kirk McGonigle	kmcgonigle@equalisgroup.org	Sidney Central School District	Education - Primary/Secondary/PreK-12	95 West Main Street	Sidney	NY	13838	607-561-7700	5/3/2021
EG-0021379	Kirk McGonigle	kmcgonigle@equalisgroup.org	South County Central School District	Education - Primary/Secondary/PreK-12	189 North Dunton Avenue	East Patchogue	NY	11772	631-730-1500	5/17/2022
EG-0021380	Kirk McGonigle	kmcgonigle@equalisgroup.org	South Huntington Union Free School District	Education - Primary/Secondary/PreK-12	60 Weston Street	Huntington Station	NY	11746	(631) 678-3017	5/19/2022
EG-0021385	Kirk McGonigle	kmcgonigle@equalisgroup.org	South Orangtown Central School District	Education - Primary/Secondary/PreK-12	160 Van Wyck Road	Blauvelt	NY	10913	845-680-1039	9/24/2021
EG-0021394	Kirk McGonigle	kmcgonigle@equalisgroup.org	Southold Union Free School District	Education - Primary/Secondary/PreK-12	420 Oaklawn Avenue	Southold	NY	11971	631-795-5400	5/5/2022
EG-0021395	Kirk McGonigle	kmcgonigle@equalisgroup.org	Southwestern Central School District at Jamestown	Education - Primary/Secondary/PreK-12	600 County Touring Route 32	Jamestown	NY	14701	(716) 484-1136	9/22/2022
EG-5V4S5ST	Kirk McGonigle	kmcgonigle@equalisgroup.org	STATE UNIVERSITY OF NEW YORK	Education - Colleges & Universities	353 Broadway	Albany	NY	12246	(518) 320-1100	11/12/2015
EG-8T9N0ST	Kirk McGonigle	kmcgonigle@equalisgroup.org	State University of New York at Canton	Education - Colleges & Universities	34 Cornell Dr	Canton	NY	13617	(800) 398-7123	
EG-7T0B9ST	Kirk McGonigle	kmcgonigle@equalisgroup.org	State University of New York at Cobleskill	Education - Colleges & Universities	106 Suffolk Cir	Cobleskill	NY	12043	(518) 255-5011	
EG-7PPU4ST	Kirk McGonigle	kmcgonigle@equalisgroup.org	State University of New York at Delhi	Education - Colleges & Universities	454 Delhi Dr.	Delhi	NY	13753	(800) 963-3544	
EG-9PZS0ST	Kirk McGonigle	kmcgonigle@equalisgroup.org	State University of New York at Fredonia	Education - Colleges & Universities	280 Central Ave.	Fredonia	NY	14063	(716) 673-3111	
EG-3TMV1ST	Kirk McGonigle	kmcgonigle@equalisgroup.org	State University of New York at Oneota	Education - Colleges & Universities	108 Ravine Pkwy	Oneota	NY	13820	(607) 436-3500	
EG-3PSS6ST	Kirk McGonigle	kmcgonigle@equalisgroup.org	State University of New York at Potsdam	Education - Colleges & Universities	7060 NY-104	Oswego	NY	13126	(315) 312-2500	
EG-6TRC6ST	Kirk McGonigle	kmcgonigle@equalisgroup.org	State University of New York at Delhi	Education - Colleges & Universities	44 Pierrepont Ave	Potsdam	NY	13676	(315) 267-2000	
EG-6UIP2ST	Kirk McGonigle	kmcgonigle@equalisgroup.org	State University of New York Environmental Science and Forest	Education - Colleges & Universities	1 Forestry Drive	Syracuse	NY	13210	(315) 470-6500	
EG-9UEE9ST	Kirk McGonigle	kmcgonigle@equalisgroup.org	State University of New York Upstate Medical University	Education - Colleges & Universities	750 E. Adams St.	Syracuse	NY	13210	(315) 464-5540	
EG-0028914	Kirk McGonigle	kmcgonigle@equalisgroup.org	Stony Brook University	Education - Colleges & Universities	1500 Stony Brook Road	Stony Brook	NY	11790	631.632.6000	5/3/2022
EG-0004247	Kirk McGonigle	kmcgonigle@equalisgroup.org	Suffolk County Community College	Education - Colleges & Universities	533 College Road	Selden	NY	11784	631-451-4110	3/25/2022
EG-3C9C4SU	Kirk McGonigle	kmcgonigle@equalisgroup.org	SUNY Auxiliary Services	Education - Colleges & Universities	353 Broadway	Brooklyn	NY	11211		
EG-4ARG5SU	Kirk McGonigle	kmcgonigle@equalisgroup.org	SUNY College of Environmental Science and Forestry	Education - Colleges & Universities	1 Forestry Drive	Syracuse	NY	13210		
EG-20QL5SU	Kirk McGonigle	kmcgonigle@equalisgroup.org	SUNY Cortland	Education - Colleges & Universities	P.O. Box 2000	Cortland	NY	13210		5/13/2021
EG-08NQ4SU	Kirk McGonigle	kmcgonigle@equalisgroup.org	SUNY Downstate Medical Center	Education - Colleges & Universities	450 Clarkson Avenue	Brooklyn	NY	11203		
EG-78OE2SU	Kirk McGonigle	kmcgonigle@equalisgroup.org	SUNY Farmingdale	Education - Colleges & Universities	2350 New York 110	Farmingdale	NY	11735		
EG-4BP37SU	Kirk McGonigle	kmcgonigle@equalisgroup.org	SUNY New Paltz	Education - Colleges & Universities	1 Hawk Hill Road	New Paltz	NY	12561		
EG-18PH7SU	Kirk McGonigle	kmcgonigle@equalisgroup.org	SUNY Old Westbury	Education - Colleges & Universities	223 Store Hill Road	Old Westbury	NY	11568		
EG-90BA7SU	Kirk McGonigle	kmcgonigle@equalisgroup.org	SUNY Plattsburgh	Education - Colleges & Universities	101 Broad St	Plattsburgh	NY	12901	(518) 564-2000	
EG-4B1G4SU	Kirk McGonigle	kmcgonigle@equalisgroup.org	SUNY Polytechnic Institute	Education - Colleges & Universities	257 Fuller Road	Albany	NY	12203		
EG-0BZC3SU	Kirk McGonigle	kmcgonigle@equalisgroup.org	SUNY WATS International	Education - Colleges & Universities	200 Manchester Rd	Poughkeepsie	NY	12603		
EG-6P0D9TH	Kirk McGonigle	kmcgonigle@equalisgroup.org	The College at Brockport	Education - Colleges & Universities	350 New Campus Dr.	Brockport	NY	14420		
EG-0029363	Kirk McGonigle	kmcgonigle@equalisgroup.org	The Cooper Union	Education - Primary/Secondary/PreK-12	30 Cooper Square	New York	NY	10003		
EG-7CUV0TO	Kirk McGonigle	kmcgonigle@equalisgroup.org	Tompkins Cortland Community College	Education - Colleges & Universities	170 North Street	Dryden	NY	13053	(607) 844-8211	2/22/2022
EG-796C1TO	Kirk McGonigle	kmcgonigle@equalisgroup.org	Town of Esopus	Government - City	248 Broadway	Ulster Park	NY	12487	(845) 331-3709	9/24/2020
EG-0030342	Kirk McGonigle	kmcgonigle@equalisgroup.org	Town of Greenfield, NY	Government - City	Mailing Address PO Box 10 Green	Greenfield	NY	12833	(518) 893-7432	7/25/2022
EG-0022213	Kirk McGonigle	kmcgonigle@equalisgroup.org	Town of Perinton	Government - City	1350 Turk Hill Road	Fairport	NY	14450	(585) 223-5050	3/16/2022
EG-0029321	Kirk McGonigle	kmcgonigle@equalisgroup.org	Town of Riga	Government - City	6460 Buffalo Road	Churchville	NY	14428	(585) 293-2530	2/11/2022
EG-0030895	Kirk McGonigle	kmcgonigle@equalisgroup.org	Town of West Seneca	Government - City	1250 Union Road	West Seneca	NY	14224	(716) 674-5600	10/5/2022
EG-0030120	Kirk McGonigle	kmcgonigle@equalisgroup.org	True North Rochester Prep Charter School	Education - Primary/Secondary/PreK-12	400 Andrews Street, Suite #610	Rochester	NY	14604		6/29/2022
EG-0029985	Kirk McGonigle	kmcgonigle@equalisgroup.org	Uncommon Charter High School	Education - Primary/Secondary/PreK-12	1485 Pacific Street	Brooklyn	NY	11216	(718) 638-1868	6/29/2022
EG-0030157	Kirk McGonigle	kmcgonigle@equalisgroup.org	Uncommon Collegiate Charter High School	Education - Primary/Secondary/PreK-12	832 Marcy Avenue	Brooklyn	NY	11216	347-390-0300	6/29/2022
EG-0030154	Kirk McGonigle	kmcgonigle@equalisgroup.org	Uncommon Leadership Charter High School	Education - Primary/Secondary/PreK-12	999 Jamaica Avenue	Brooklyn	NY	11208	974-473-8780	6/29/2022





Member ID	Equalis Contact	Email Address	Account Name	Entity Type	Address	City	State	Zip	Account Phone	Join Date
EG-0030119	Kirk McGonigle	kmcgonigle@equalisgroup.org	Uncommon NYC Charter Schools	Education - Primary/Secondary/PreK-12	507 MacDonough Street	Brooklyn	NY	11233		
EG-0030164	Kirk McGonigle	kmcgonigle@equalisgroup.org	Uncommon Prep Charter High School	Education - Primary/Secondary/PreK-12	6565 Flatlands Ave	Brooklyn	NY	11236	718-307-5077	6/29/2022
EG-0030113	Kirk McGonigle	kmcgonigle@equalisgroup.org	Uncommon Schools	Education - Primary/Secondary/PreK-12	55 Broad Street	New York	NY	10004	201-736-6705	6/29/2022
EG-0021441	Kirk McGonigle	kmcgonigle@equalisgroup.org	Uniondale Union Free School District	Education - Primary/Secondary/PreK-12	933 Goodrich Street	Uniondale	NY	11553	516-560-8800	7/15/2022
EG-0029392	Kirk McGonigle	kmcgonigle@equalisgroup.org	United States Tennis Association, Inc	Non-Profit Organization	70 West Red Oak Lane	White Plains	NY	10604	(914) 696-7000	2/25/2022
EG-1PW11UN	Kirk McGonigle	kmcgonigle@equalisgroup.org	University at Albany	Education - Colleges & Universities	1400 Washington Ave	Albany	NY	12222	(518) 442-3300	
EG-9T3L6UN	Kirk McGonigle	kmcgonigle@equalisgroup.org	Universitv at Buffalo	Education - Colleges & Universities	12 Capen Hall	Buffalo	NY	14260	(716) 645-2000	
EG-0021453	Kirk McGonigle	kmcgonigle@equalisgroup.org	Valley Stream 13 School District	Education - Primary/Secondary/PreK-12	585 N CORONA AVE	VALLEY STREAM	NY	11580		4/14/2022
EG-0028282	Kirk McGonigle	kmcgonigle@equalisgroup.org	Vassar College	Education - Colleges & Universities	124 Raymond Ave Box 17	Poughkeepsie	NY	12604		1/14/2021
EG-55HS5VI	Kirk McGonigle	kmcgonigle@equalisgroup.org	Village of Newark, NY	Government - City	100 East Miller Street	Newark	NY	14513	(315) 331-4770	11/20/2019
EG-0004651	Kirk McGonigle	kmcgonigle@equalisgroup.org	Village of Penn Yan, NY	Government - City	111 Elm StreetPO. Box 426	Penn Yan	NY	14527	(315) 536-3015	9/13/2021
EG-0029987	Kirk McGonigle	kmcgonigle@equalisgroup.org	Village of Shortsville, NY	Other	6 East Main Street	Shortsville	NY	14548	(585) 289-6104	6/1/2022
EG-0030025	Kirk McGonigle	kmcgonigle@equalisgroup.org	Virginia Cooperative Extension - NY	Education - Colleges & Universities	615 Willow Avenue	Ithaca	NY	14850		6/9/2022
EG-0021468	Kirk McGonigle	kmcgonigle@equalisgroup.org	Wappingers Central School District	Education - Primary/Secondary/PreK-12	25 Corporate Park Drive, P.O. Box	Hopewell Junction	NY	12533	845.298.5000	4/19/2022
EG-0021495	Kirk McGonigle	kmcgonigle@equalisgroup.org	Wellsville Central School	Education - Primary/Secondary/PreK-12	126 West State Street	Wellsville	NY	14895	(585) 596-2170	6/29/2022
EG-78TJ7WE	Kirk McGonigle	kmcgonigle@equalisgroup.org	Westchester Community College	Education - Colleges & Universities	75 Grasslands Road	Valhalla	NY	10595		
EG-0030167	Kirk McGonigle	kmcgonigle@equalisgroup.org	Williamsburg Collegiate Charter School	Education - Primary/Secondary/PreK-12	157 Wilson Street	Brooklyn	NY	11211	718-302-4018	9/14/2022